

CD-ROM

The CD-ROM, which is inserted in the cover, contains the user manual of the SPX10, SPX15 and SPX20 hose pumps. The CD-ROM also contains a replacement instruction for the pump hose. This replacement instruction is only for users that are familiar with the replacement procedures in the user manual.

System requirements

The program on CD-ROM requires a PC with the following minimum system requirements:

- Pentium I 100 MHz
- 64 MB internal memory
- 256 colors

The following software must be installed on the PC:

- Adobe Acrobat Reader
- Internet Explorer

How to use the CD-ROM

- 1 Put the CD-ROM in the CD drive.
- 2 Close the CD drive.
The CD-ROM will start automatically.
- 3 Wait until the various language versions appear on screen.
- 4 Select the required language (click 1x with the left mouse button).
The program Adobe Acrobat Reader will automatically start and the required user manual appears on screen.

Shortcuts

In the left margin you will find the various chapters and paragraphs. These can be accessed directly by clicking on the required chapter or paragraph.

In the text you will find hyperlinks to chapters or paragraphs. These hyperlinks are linked with the required chapters or paragraphs. By clicking a shortcut the required chapter or paragraph appears on screen.

Hose pump series SPX10, SPX15 and SPX20

Manual

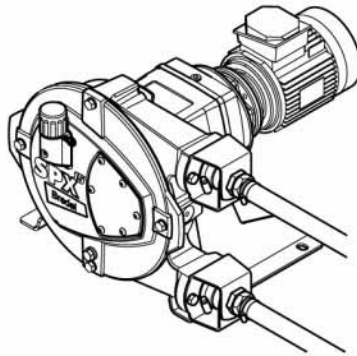

© 2010 Watson-Marlow Bredel B.V.

All rights reserved.

The information provided herein may not be reproduced and/or published in any form, by print, photocopy, microfilm or any other means whatsoever (electronically or mechanically) without the prior written authorization of Watson-Marlow Bredel B.V.

The information provided can be changed without prior notification. Watson-Marlow Bredel B.V. or one of its representatives cannot be held liable for possible damage resulting from use of this manual. This is an extensive limitation of the liability which applies to all damage, inclusive of (without limitation) compensating, direct, indirect or consequential damage, loss of data, income or profit, loss or damage to possessions and claims of third parties.

Watson-Marlow Bredel B.V. provides the information in this manual "as is" and does not take any responsibility and does not give any guarantee on this manual or its content. Watson-Marlow Bredel B.V. rejects all responsibilities and guarantees. Furthermore, Watson-Marlow Bredel B.V. does not take responsibility for and does not guarantee that the information in this manual is accurate, complete or up to date.

Names, trade names, brands, etc. used by Watson-Marlow Bredel B.V. may not, as per the legislation concerning the protection of trade names, be considered as available.

CONTENTS

1 GENERAL

1.1	<i>How to use this manual</i>	8
1.2	<i>Original instructions</i>	8
1.3	<i>Other supplied documentation</i>	8
1.4	<i>Service and support</i>	8
1.5	<i>Environment and disposal of waste</i>	9

2 SAFETY

2.1	<i>Symbols</i>	10
2.2	<i>Intended use</i>	10
2.3	<i>Use in potentially explosive atmospheres</i>	11
2.4	<i>Responsibility</i>	11
2.5	<i>Qualification of the user</i>	12
2.6	<i>Regulations and instructions</i>	12

3 WARRANTIES

4 DESCRIPTION

4.1	<i>Identification of the product</i>	14
4.1.1	<i>Identification of the product</i>	14
4.1.2	<i>Identification of the pump</i>	14
4.1.3	<i>Identification of the gearbox</i>	14
4.1.4	<i>Identification of the electric motor</i>	15
4.1.5	<i>Identification of the frequency controller</i>	15
4.1.6	<i>Identification of the pump hose</i>	15
4.2	<i>Construction of the pump</i>	16
4.3	<i>Operation of the pump</i>	17
4.4	<i>Pump hose</i>	18
4.4.1	<i>General</i>	18
4.4.2	<i>Hose compression force adjustment</i>	19
4.4.3	<i>Lubrication and cooling</i>	19
4.5	<i>Gearbox</i>	19
4.6	<i>Electric motor</i>	20
4.7	<i>Frequency controller</i>	20
4.8	<i>Available options</i>	20

5	INSTALLATION	
5.1	<i>Unpacking</i>	21
5.2	<i>Inspection</i>	21
5.3	<i>Installation conditions</i>	21
5.3.1	Ambient conditions	21
5.3.2	Set-up	21
5.3.3	Pipework	22
5.3.4	Frequency controller	23
5.4	<i>Lifting and moving the pump</i>	24
5.5	<i>Placing the pump</i>	24
6	COMMISSIONING	
6.1	<i>Preparations</i>	25
6.2	<i>Commissioning</i>	25
7	MAINTENANCE	
7.1	<i>General</i>	27
7.2	<i>Maintenance and periodic inspections</i>	27
7.3	<i>Additional maintenance in potentially explosive environments</i>	29
7.4	<i>Cleaning pump hose</i>	29
7.5	<i>Changing lubricant</i>	30
7.6	<i>Replacing pump hose</i>	30
7.6.1	Removing pump hose	30
7.6.2	Cleaning the pump head	32
7.6.3	Fitting the pump hose	32
7.7	<i>Exchanging replacement parts</i>	34
7.7.1	Replacing rotor, bearings and seal ring	34
7.8	<i>Fitting options</i>	38
7.8.1	Fitting a high-level float switch	38
7.8.2	Fitting revolution counter	38
8	STORAGE	
8.1	<i>Hose pump</i>	39
8.2	<i>Pump hose</i>	39
9	TROUBLESHOOTING	

10 HAZARDOUS ENVIRONMENTS (ATEX)

10.1	<i>ATEX compliance</i>	45
10.2	<i>Identification</i>	45
10.2.1	<i>Pump head</i>	45
10.2.2	<i>Gearbox</i>	46
10.2.3	<i>Electric motor</i>	46
10.2.4	<i>Frequency controller</i>	46

11 SPECIFICATIONS

11.1	<i>Pump head</i>	47
11.1.1	<i>Performance</i>	47
11.1.2	<i>Materials</i>	48
11.1.3	<i>Surface treatment</i>	49
11.1.4	<i>Lubricant table pump</i>	49
11.1.5	<i>Weights</i>	50
11.1.6	<i>Torque figures</i>	51
11.2	<i>Gearbox</i>	52
11.3	<i>Electric motor</i>	52
11.4	<i>Watson-Marlow Bredel Variable Frequency Drive (VFD) (optional)</i>	52
11.5	<i>Parts list</i>	53
11.5.1	<i>Overview</i>	53
11.5.2	<i>Cover assembly</i>	54
11.5.3	<i>Pump head assembly</i>	55
11.5.4	<i>Support assembly</i>	56
11.5.5	<i>Hose nipple assembly (PTFE/PDVF)</i>	57
11.5.6	<i>Hose or threaded nipple assembly (AISI 316)</i>	58
11.5.7	<i>Flange assembly (1)</i>	59
11.5.8	<i>Flange assembly (2)</i>	60
11.5.9	<i>Lubricants</i>	61

1 GENERAL

1.1 How to use this manual

This manual is intended as a reference book by means of which qualified users are able to install, commission and maintain the hose pumps mentioned on the front cover.

1.2 Original instructions

The original instructions for this manual have been written in English. Other language versions of this manual are a translation of the original instructions.

1.3 Other supplied documentation

Documentation of components such as the gearbox, the motor and the frequency controller is normally not included in this manual. However, if additional documentation is supplied, you must follow the instructions in this additional documentation.

1.4 Service and support

For information with respect to specific adjustments, installation, maintenance or repair jobs which fall beyond the scope of this manual, contact your Watson-Marlow Bredel representative. Make sure you have the following data at hand:

- Serial number hose pump
- Article number pump hose
- Article number gearbox
- Article number electric motor
- Article number frequency controller

You will find these data on the identification plates or stickers of the pump head, the pump hose, the gearbox and the electric motor. Refer to § 4.1.1.

1.5 Environment and disposal of waste

**CAUTION**

Always observe the local rules and regulations with respect to processing (non reusable) parts of the hose pump.

Inquire within your local government about the possibilities for reuse or environment friendly processing of packaging materials, (contaminated) lubricant and oil.

2 SAFETY

2.1 Symbols

In this manual the following symbols are used:

	WARNING Procedures which, if not carried out with the necessary care, may result in serious damage to the hose pump or in serious bodily harm.
--	--

	CAUTION Procedures which, if not carried out with the necessary care, may result in serious damage to the hose pump, the surrounding area or the environment.
--	---

	Remarks, suggestions and advice.
---	----------------------------------

	WARNING Procedures, remarks, suggestions or advice which refer to use in potentially explosive atmospheres in accordance with the ATEX Directive 94/9/EC.
--	---

2.2 Intended use

The hose pump is exclusively designed for pumping suitable products. Every other or further use is not in conformance with the intended use.

The "Intended use" as laid down in EN 292-1 is "... the use for which the technical product is intended in accordance with the specifications of the manufacturer, inclusive of his indications in the sales brochure". In case of doubt it is the use which appears to be its intended use judging from the construction, execution

and function of the product. Observing the instructions in the user's documentation also belongs to intended use.

Only use the pump in accordance with the intended use described above. The manufacturer cannot be held responsible for damage or harm resulting from misuse. If you want to change the application of your hose pump, contact your Watson-Marlow Bredel representative first.

2.3 Use in potentially explosive atmospheres

Refer to chapter 10 for a description of pump configurations that are suitable in a potentially explosive atmosphere. The pump mentioned in this manual is suitable for use in a potentially explosive atmosphere. For use in Europe, the pump complies with the European Directive 94/9/EC (ATEX).



Group II Appliances, category 2 GD b c k
T5

Use in Potentially explosive atmospheres requires special configuration of the pump unit. Contact your Watson-Marlow Bredel representative for use in explosive atmospheres.

2.4 Responsibility

The manufacturer does not accept any responsibility for damage or harm caused by not (strictly) observing the safety regulations and instructions in this manual and the also supplied documentation, or by negligence during installation, use, maintenance and repair of the hose pumps mentioned on the front cover. Depending on the specific working conditions or accessories used, additional safety instructions can be required.

Immediately contact your Watson-Marlow Bredel representative, if you noticed a potential danger while using your hose pump.

**WARNING**

The user of the hose pump is always fully responsible for observing the local valid safety regulations and directives. Observe these safety regulations and directives when using the hose pump.

2.5 Qualification of the user

The installation, use and maintenance of the hose pump is only reserved for well trained and qualified users. Temporary staff and persons in training may only use the hose pump under the supervision and responsibility of well trained and qualified users.

2.6 Regulations and instructions

- Everyone who works with the hose pump must be aware of the contents of this manual and observe the instructions with great care.
- Never change the order of the actions to be carried out.
- Always store the manual near the hose pump.

3 WARRANTIES

The manufacturer offers a 2-year warranty on proper workmanship of all parts of the hose pump. Exclusion is made for normal wear and tear of consumables, such as pump hoses, lubricant, hose clamps, pressing shoes, ball bearings, wear ring, and seals, or parts which have been misused or damaged through negligence.

This manufacturer's warranty is null and void for any user who has substituted the parts of an alternate manufacturer into a Watson-Marlow Bredel hose pump.

Damaged parts may be returned to the manufacturer for warranty analysis. If failure was determined caused by faulty workmanship, the manufacturer will repair or replace the faulty component.

The parts must be accompanied by a fully completed and signed health and safety form, as present in the back of this manual. The form must be applied to the outside of the shipping carton.

Parts which have been contaminated or which have been corroded by chemicals or other substances, which can pose a health risk, must be cleaned before they are returned to the manufacturer. Furthermore, it should be indicated on the health and safety form, which specific cleaning procedure has been followed, and it should be indicated that the equipment has been decontaminated. The safety form is required at all items, even if the parts have not been used.

Warranties purporting to be on behalf of Watson-Marlow Bredel B.V. made by any person, including representatives of Watson-Marlow Bredel B.V., its subsidiaries, or its distributors, which do not accord with the terms of this warranty shall not be binding upon Watson-Marlow Bredel B.V. unless expressly approved in writing by a Director or Manager of Watson-Marlow Bredel B.V.

4 DESCRIPTION

4.1 Identification of the product

4.1.1 Identification of the product

The hose pump can be identified based on the identification plates or stickers on:

- A:** Pump head
- B:** Gearbox
- C:** Electric motor
- D:** Pump hose
- E:** Frequency controller (option)

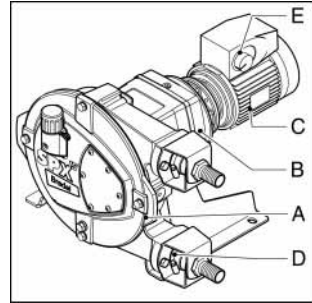

4.1.2 Identification of the pump

The identification plate on the pump head contains the following data:

- A:** Pump model
- B:** Serial number

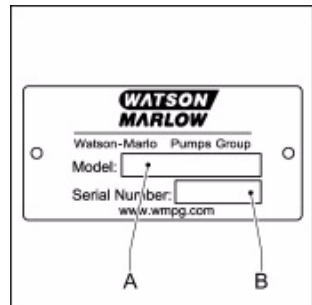

4.1.3 Identification of the gearbox

The identification plate on the gearbox contains the following data:

- A:** Article number
- B:** Serial number
- C:** Type number
- D:** Reduction
- E:** Number of revolutions per minute
- F:** Lubricant type upon delivery

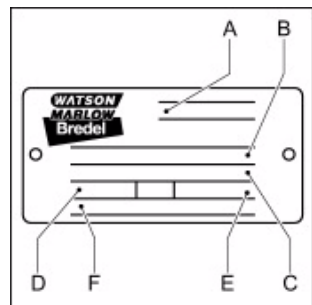

4.1.4 Identification of the electric motor

The identification plate on the electric motor contains the following data:

- A:** Type number
- B:** Serial number
- C:** Article number
- D:** Mains
- E:** Frequency
- F:** Speed
- G:** Power
- H:** Power factor
- I:** Current

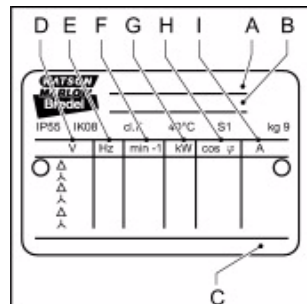

4.1.5 Identification of the frequency controller

The identification plate on the Watson-Marlow Bredel Variable Frequency Drive (VFD) contains the following data:

- A:** Article number

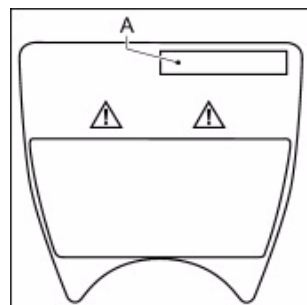

4.1.6 Identification of the pump hose

The identification sticker on the pump hose contains the following data:

- A:** Order number
- B:** Internal diameter
- C:** Type of material of inner liner
- D:** Maximum permissible working pressure
- E:** Production code

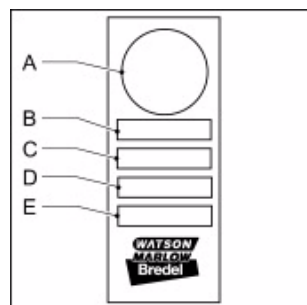

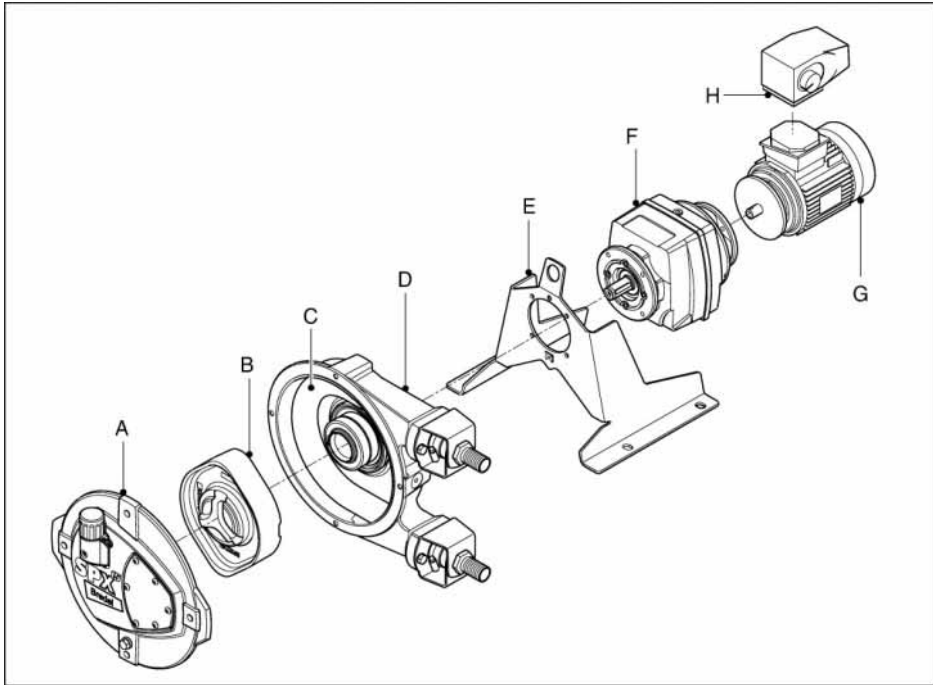
4.2 Construction of the pump

- A:** Cover
- B:** Rotor
- C:** Pump hose
- D:** Pump housing
- E:** Support
- F:** Gearbox
- G:** Electric motor
- H:** Frequency controller

4.3 Operation of the pump

The heart of the pump head consists of a specially constructed pump hose (A) which lies contorted against the inside of the pump housing (B). Both ends of the hose are connected to the suction and discharge lines (C). A bearing-mounted rotor (D) with two facing integral pressing shoes (E) is in the centre of the pump head.

In phase 1 the lower shoe compresses the pump hose by the rotational movement of the rotor, forcing the fluid through the hose. As soon as the shoe has passed, the hose recovers to its original shape due to the mechanical properties of the material.

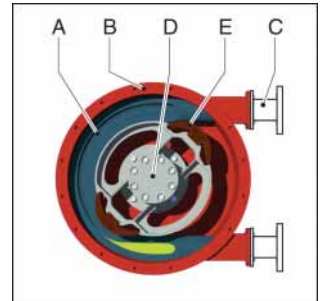

In phase 2 the product is drawn into the hose by the (continuous) turning motion of the rotor.

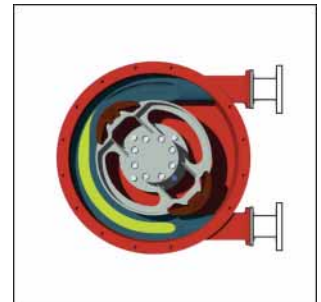

In phase 3, the second integral pressing shoe will subsequently compress the pump hose. Due to the continuous rotating movement of the rotor not only new product is sucked in, but also the already present product is pressed out by the shoe. When the first shoe runs from the pump hose, the second shoe has already closed the pump hose and the product is prevented from flowing back. This method of liquid displacement is also known as the "positive displacement principle".

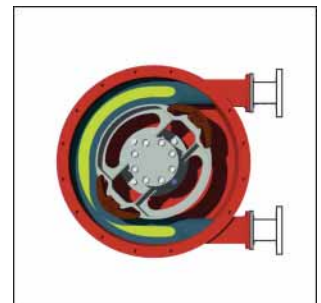

4.4 Pump hose

4.4.1 General

- A:** Outer extruded layer made of natural rubber
B: Two nylon reinforcement layers
C: Inner extruded liner

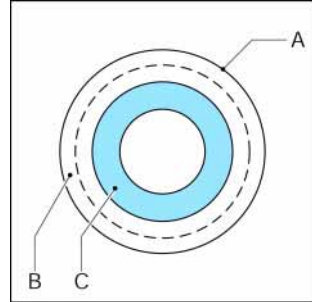

The pump hose liner material should be chemically resistant with the product to be pumped. Dependent on the specific requirements of your application a corresponding pump hose must be selected. For each pump model various hose types are available.

The material of the inner liner of the pump hose determines the hose type. Each hose type is marked by a unique color code.

Hose type	Material	Color code
NR	Natural rubber	Purple
NBR	Buna	Yellow
EPDM	EPDM	Red

	<p>Consult your Watson-Marlow Bredel representative for more detailed information about the chemical and temperature resistance of pump hoses.</p>
--	--

The Watson-Marlow Bredel pump hoses have been carefully machined, therefore there are minimum tolerances in wall thickness. It is very important to guarantee the correct compression of the pump hose, because:

- When the compression is too high, it creates a too high load of the pump and pump hose, which may result in a reduction of the life of the pump hose and bearings.

- When the compression is too low, this will result in loss of capacity and backflow. Backflow results in a reduction of the life of the pump hose.

4.4.2 Hose compression force adjustment

The compression force of the pump hose can be adjusted by installing a rotor with a different dimension between the tips of the integral pressing shoes. The rotor is chosen to achieve an optimal life of the pump hose for the intended use of the hose pump. If you want to change the application of your hose pump, contact your Watson-Marlow Bredel representative.

4.4.3 Lubrication and cooling

The pump head, in which the rotor and pump hose can be found, is filled with Watson-Marlow Bredel Genuine Hose Lubricant. This lubricant lubricates the movement between the hose and the pressing shoes and dissipates the generated heat via the pump housing and the cover.

The lubricant is food grade. Refer to § 11.1.4 for the required quantity and NSF registration.



Consult your Watson-Marlow Bredel representative for lubrication recommendations when operating the hose pump below 2 rpm.

4.5 Gearbox

The hose pump types described in this manual use helical gearbox units. The gearboxes are fitted with a flange connection. Refer to § 11.2 for specifications. If the pump is to be used in potentially explosive atmospheres, refer to chapter 10.

4.6 Electric motor

If the electric motor has been standard supplied by the manufacturer, it is a standardized squirrel-cage motor. Refer to § 11.3 for specifications. If the pump is to be used in potentially explosive atmospheres, refer to chapter 10.

4.7 Frequency controller

Refer to the also supplied documentation of the supplier and § 11.4. If the pump is to be used in potentially explosive atmospheres, refer to chapter 10.

4.8 Available options

The following options are available for the hose pump:

- High (lubricant) level float switch
- Revolution counter
- High or low pressure rotor
- Frequency controller
- Special configuration for use in explosive atmospheres

5 INSTALLATION

5.1 Unpacking

When unpacking carefully follow the instructions as given on the packaging or on the hose pump.

5.2 Inspection

Check that your delivery is correct and check it for any transport damage. Refer to § 4.1.1. Report any damage immediately to your Watson-Marlow Bredel representative.

5.3 Installation conditions

5.3.1 Ambient conditions

Make sure that the hose pump is in an area where the ambient temperature during operation is not lower than -20 °C (-4 °F) and not higher than +45 °C (+113 °F).

5.3.2 Set-up

- The pump materials and protective layers are suitable for indoor set-up and a protected outdoor set-up. Under certain conditions the pump is suitable for limited outdoor set-up or a salty or aggressive atmosphere. Consult your Watson-Marlow Bredel representative for more information.
- Make sure that the floor surface is horizontal and has a maximum slope of 1 mm per meter (0.012 in per foot).
- Make sure that there is sufficient room around the pump to carry out the necessary maintenance activities.
- Make sure that the room is sufficiently ventilated, so that the heat developed by the pump and drive can be discharged. Keep some

distance between the ventilation cover of the electric motor and wall to enable the supply of necessary cooling air.

5.3.3 Pipework

When determining and connecting suction and discharge lines consider the following points:

- The bore size of the suction and discharge lines must be larger than the bore size of the pump hose. For more information consult your Watson-Marlow Bredel representative.
- Limit the presence of sharp bends in the discharge line. Make sure that the radius of the bent discharge line is as large as possible (preferably 5S). It is recommended to use Y-connections instead of T-connections.
- It is recommended to use a minimum of three quarters (3/4) of the hose length as flexible hose in the suction or discharge line. This avoids the need to remove the connection lines when changing a pump hose.
- Keep the delivery and suction lines as short and direct as possible.
- Select the correct mounting material for flexible hoses and make sure that the installation is suited for the design pressure of the system.
- Prevent any possibilities of exceeding the maximum working pressure of the hose pump. Refer to § 11.1.1. If necessary fit a pressure relief valve.



CAUTION

Consider the maximum permissible working pressure on the discharge side. Exceeding the maximum working pressure may lead to serious damage to the pump.

- Make sure that the maximum forces on the flanges are not exceeded. The permissible loads are given in the following table.

Maximum permissible loads [N] on the pump connections			
Force	SPX10	SPX15	SPX20
F1	600	600	600
F2	120	120	120
F3	300	300	300

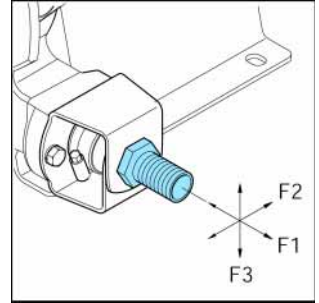

5.3.4 Frequency controller



WARNING

A frequency controller that is fitted *without the manual control* can start automatically when power is applied.

If the hose pump is fitted with a frequency controller, consider the following points:

- Take precautions so the motor does not re-start automatically after an unscheduled stop. In the event of a power or mechanical failure, the frequency controller controls the motor to stop. When the cause of the failure is removed, the motor can restart automatically. The automatic restart can be dangerous in certain pump installations.
- All control cables outside the enclosure must be shielded and have a cross sectional area between 0.22 and 1 mm². The shielding must be connected to earth at both ends.

5.4 Lifting and moving the pump

For lifting and moving the hose pump, the pump support has a lifting eye (A).

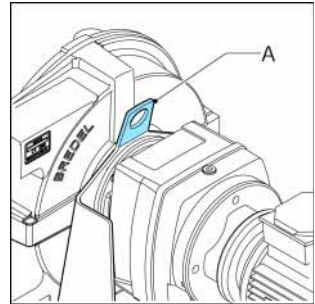

The complete hose pump, i.e. pump head, gearbox and electric motor, must be lifted using the lifting eye plus additional support using suitably rated straps or slings (A). For the weights, refer to § 11.1.5.

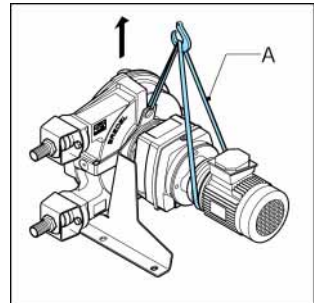

WARNING

If the pump is to be lifted ensure that all standard lifting practices are adhered to and carried out by qualified personnel only.

5.5 Placing the pump

Position the pump on a horizontal surface. Use suitable anchor bolts to attach the pump to the floor surface.

6 COMMISSIONING

6.1 Preparations

**WARNING**

A frequency controller that is fitted *without the manual control* can start automatically when power is applied.

**WARNING**

Disconnect and lock the power supply to the pump drive before any work is carried out.

Wait two minutes to make sure that the capacitors have discharged. This is necessary when the motor is fitted with a frequency controller and has single phase power supply.

1. Connect the electric motor and, if present, the frequency controller in conformance with the locally applicable rules and regulations. Refer to § 5.3.4. Have the electrical installation work be carried out by qualified personnel.
2. Check that the lubricant level is above the minimum level line in the inspection window. If necessary refill Watson-Marlow Bredel Genuine Hose Lubricant via the breather plug. See also § 7.5.
3. Check the rotation of the rotor.

6.2 Commissioning

1. Connect the pipework. Make sure that there are no obstructions such as closed valves.
2. Switch on the hose pump.

3. Check the rotation of the rotor.
4. Check the capacity of the hose pump. If the capacity differs from your specification, follow the instructions in chapter 9 or consult your Watson-Marlow Bredel representative.
5. Check the capacity range of the frequency controller. In case of any deviations consult the documentation of the supplier.
6. Check the hose pump in accordance with points 2 to 4 of the maintenance table from § 7.2.

7 MAINTENANCE

7.1 General

**WARNING**

Disconnect and lock the power supply to the pump drive before any work is carried out.

Wait two minutes to make sure that the capacitors have discharged. This is necessary when the motor is fitted with a frequency controller and has single phase power supply.

**WARNING**

Only use original Watson-Marlow Bredel parts when maintaining the hose pump. Watson-Marlow Bredel cannot guarantee correct operation and any consequential damage that occurs from the use of non-original Watson-Marlow Bredel components. See also chapters [2](#) and [3](#).

7.2 Maintenance and periodic inspections

The following diagram shows the maintenance and periodic inspection that need to be carried out on the hose pump to guarantee optimal safety, operation and life of the pump.

Point	Action	To be carried out	Remark
1	Check the lubricant level.	Before startup of the pump and on a scheduled interval during operation.	Make sure that the lubricant level is above the minimum level line in the inspection window. If necessary refill the lubricant. See also § 7.5.
2	Check the pump head for any leakage of lubricant around the cover, the brackets and the rear of the pump head.	Before startup of the pump and on a scheduled interval during operation.	See § 9.
3	Check the gearbox for any leakage.	Before startup of the pump and on a scheduled interval during operation.	In case of leakage consult your Watson-Marlow Bredel representative.
4	Check pump for deviating temperature or strange noises.	On a scheduled interval during operation.	See § 9.
5	Check rotor with integral pressing shoes for excessive wear.	When replacing the pump hose.	See § 7.6.
6	Internal cleaning of the pump hose.	Cleaning of the system or product change.	See § 7.4.
7	Replacing pump hose.	Preventive, this means after 75% of the hose life of the first hose.	See § 7.6.
8	Changing lubricant.	After every 2 nd hose change or after 5,000 service hours, whichever comes first or after hose rupture.	See § 7.5
9	Replacing seal ring.	If necessary.	See § 7.7.1.

Point	Action	To be carried out	Remark
10	Replacing rotor with integral pressing shoes.	Wear on the running surface of the pump hose and/or seal ring.	
11	Replacing bearings.	If necessary.	See § 7.7.1.

7.3 Additional maintenance in potentially explosive environments

The following diagram shows the additional maintenance and periodic inspections that need to be carried out on the hose pump to guarantee optimal safety, operation and life of the pump in a potentially explosive environment.

Point	Action	To be carried out	Remark
1	Replacing bearings.	After 40,000 hours service or when damage is suspected.	See § 7.7.1.
2	Cleaning the hose pump.	In potentially explosive (dust) atmospheres, the dust must be removed regularly.	

7.4 Cleaning pump hose

The inside of the pump hose can be easily cleaned by rinsing the pump with clean water. If a cleaning fluid is added to the water, it must be checked that the hose liner material is resistant to that. Also note that the pump hose can resist the cleaning temperature. Special cleaning balls (pigs) are also available (inform with your Watson-Marlow Bredel representative).

7.5 Changing lubricant

1. Place a tray (A) under the drain plug in the cover of the pump. Remove the drain plug (B). Catch the lubricant from the pump housing in the tray. Position the drain plug and tighten it firmly.

2. The pump housing can be filled with lubricant via the breather (A) on the cover. For this purpose remove the breather cap (B) and position a funnel (C) in the breather. Pour the lubricant in the pump housing via the funnel.

3. Keep on pouring until the lubricant level has risen above the level line in the inspection window. Place breather cap.

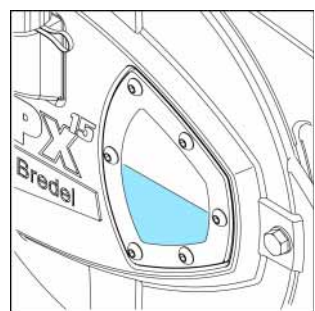
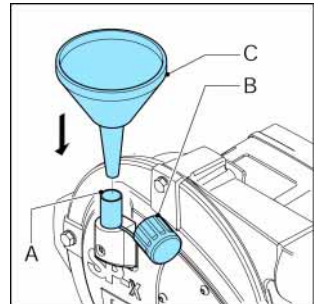
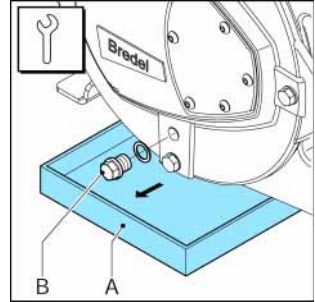

	For the required quantity of lubricant, refer to § 11.1.4.
--	--

7.6 Replacing pump hose

7.6.1 Removing pump hose

1. Isolate the pump from the electrical supply.

2. Close any shut-off valves in both the suction and discharge line to minimize product loss.

3. Place a tray (A) under the drain plug in the bottom of the pump head. The tray must be large enough to contain the lubricant, possibly contaminated with product fluid, from the pump head. Remove the drain plug (B). Catch the lubricant from the pump housing in the tray. Check that the breather mounted on the cover is not obscured. Position the drain plug and tighten it firmly.
4. Disconnect the suction and discharge lines.
5. Loosen hose clamp (A) of both the inlet and outlet ports by loosening bolt (B).
6. Loosen the retaining bolts (A) of the bracket (B) and remove the bolts.
7. Pull the bracket and hose clamp from the hose. Repeat steps 6 to 7 for both the inlet and discharge ports.
8. Switch on the electrical supply.
9. Power out the hose (A) from the pump chamber by jogging the drive motor.

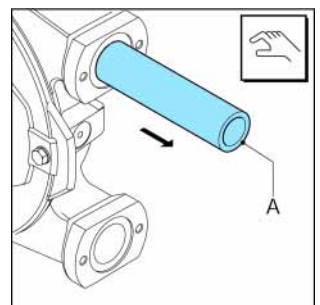
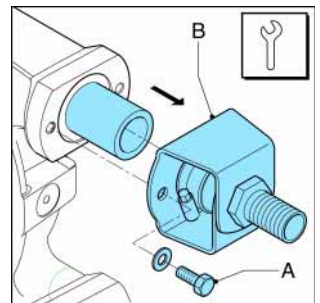
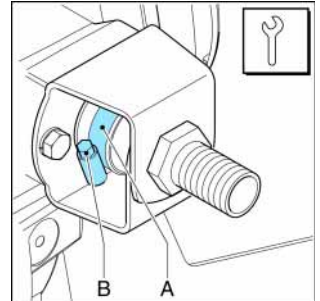
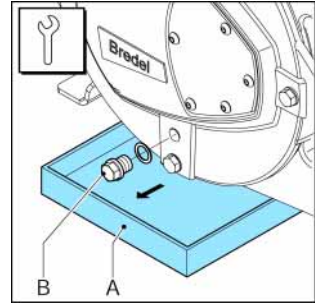

WARNING

During jogging the drive:

- Do not stand in front of the pump ports.
- Do not try to guide the hose by hand.

7.6.2 Cleaning the pump head

1. Isolate the pump from the electrical supply.
2. Remove the cover (B) by loosening the retaining bolts (A).
3. Check the gasket (C) and replace it if necessary.
4. Rinse the pump head with clean water and remove all residues. Make sure that no rinsing water remains in the pump head.
5. Check the rotor for wear or damage and replace the rotor if necessary. Also see the maintenance diagram in § 7.2.

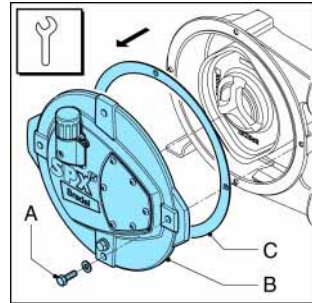

	<p>CAUTION</p> <p>When the rotor is worn the compression force of the hose decreases. If the compression force is too low, this results in a loss of capacity by the backflow of the liquid to be pumped.</p> <p>Backflow results in a reduction of the life of the pump hose.</p>
--	---

6. Replace the cover and fasten the retaining bolts with the correct torque. Refer to § 11.1.6.
7. Switch on the electrical supply to the pump.

7.6.3 Fitting the pump hose

1. Clean the (new) pump hose on the outside and fully lubricate it with Watson-Marlow Bredel Genuine Hose Lubricant.

2. Fit the pump hose (A) via one of the ports.
3. Let the motor run to let the rotor pull the hose in the pump housing. Stop the motor when the hose sticks out equally from both sides of the pump housing.

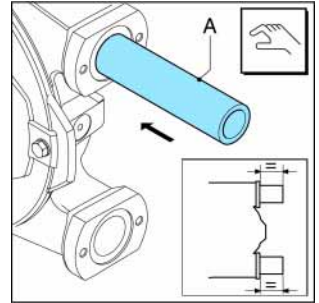

WARNING

During jogging the drive:

- Do not stand in front of the pump ports.
- Do not try to guide the hose by hand.

4. Check that the rubber bushes (A) are not deformed or damaged and replace them if necessary.
5. Check that the hose clamps (B) are not damaged and replace them if necessary.

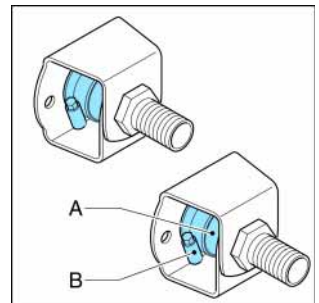

6. First fit the inlet port.
Push the bracket (A) and the hose clamp (B) over the hose together. Align the holes in the bracket with the ones at the front of the port. Position the two retaining bolts (C) and tighten them. Make sure the bolts are tightened with the correct torque. Refer to § 11.1.6.

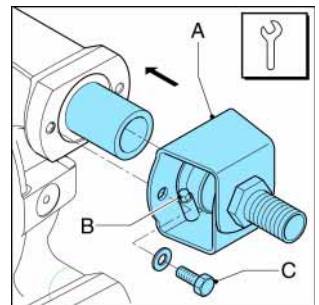

7. Fit the suction line.

8. Turn the rotor in such a way that the hose (A) is pressed firmly against the bracket (B).

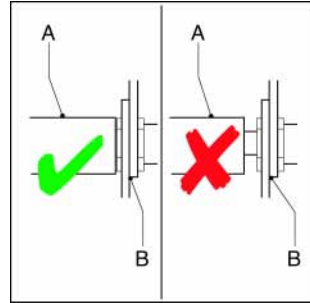

9. Tighten the bolt (A) of the hose clamp (B). Make sure the bolt is tightened with the correct torque. Refer to § 11.1.6.

10. Now fit the other port. For this port proceed in the same way as described above for the inlet port.

11. Fill the pump housing with Watson-Marlow Bredel Genuine Hose Lubricant. Refer to § 7.5.

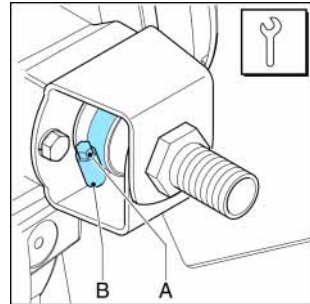

7.7 Exchanging replacement parts

7.7.1 Replacing rotor, bearings and seal ring

1. Remove the pump hose. Refer to § 7.6.1.
2. Isolate the pump from the electrical supply.
3. Remove the cover (B) by loosening the retaining bolts (A).
4. Check the gasket (C) and replace it if necessary.

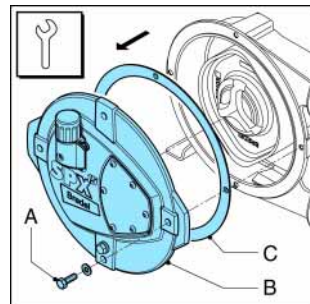

5. Put the hose pump on blocks. Make sure the space between the blocks is wide enough for the rotor to fall.

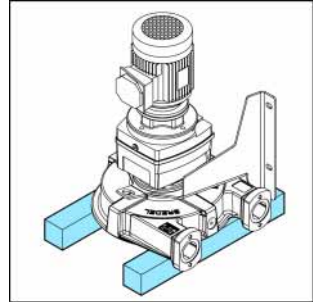

6. Remove the nuts (B), the washers (C) and the pump drive (A).

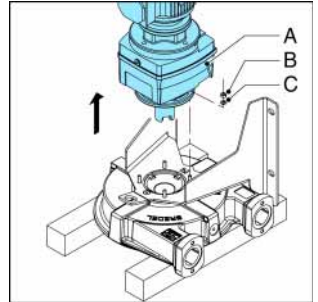

7. Put a plastic or wooden drive pin (A) on the rotor.

8. Hit the drive pin firmly with a hammer to remove the rotor.

9. Put the hose pump upright on the support.

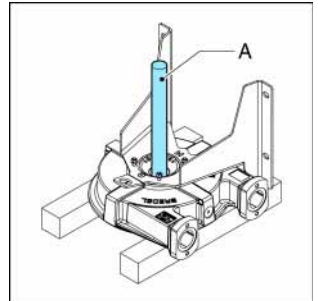

10. Dismount the circlip (A) with the correct tool.

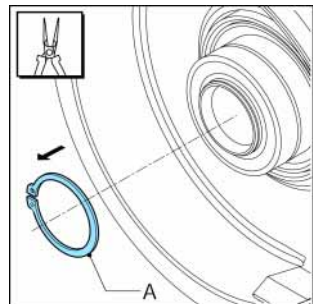

11. Dismount the bearings (A), the spacer ring (B) and the retaining ring (C) with the correct tool. Clean the hub.

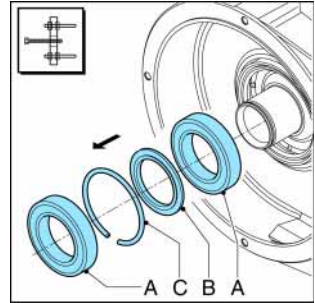

12. Remove the seal ring (A). Clean and degrease the bore.

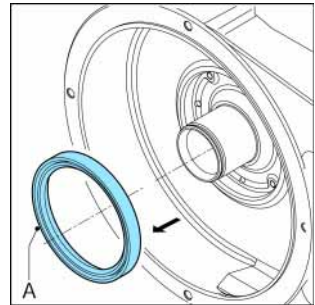

13. Fit a new seal ring (A) using good engineering practices. The seal ring must be fitted in the correct orientation (B). Make sure that the open side points to the pump cover.

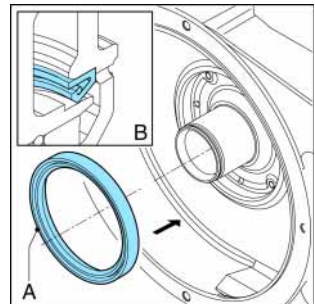

14. Slightly oil the inner ring of the (new) bearings and the seat on the hub. Fit the bearings and the rings. The bearings are placed on the hub with a slight interference fit. Use a pressing tool to press the bearings on the hub.

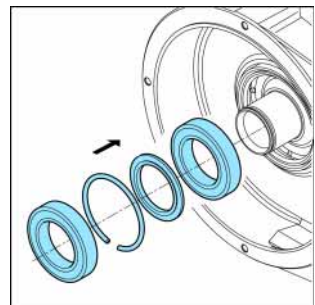

15. Mount the circlip (A).

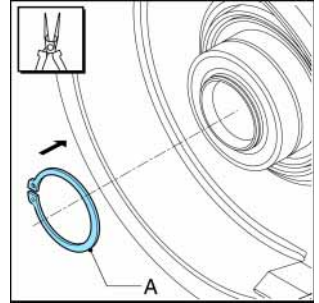

16. Fit the rotor (A). The rotor is placed on the bearings with a loose fit. Press the rotor on the hub until it clicks on the retaining ring.

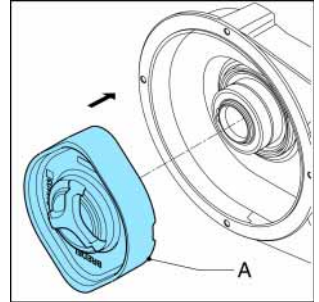

17. Put the hose pump on two blocks.

18. Fit the pump drive (A) with the nuts (B) and washers (C). Tighten to the specified torque settings. Refer to § 11.1.6.

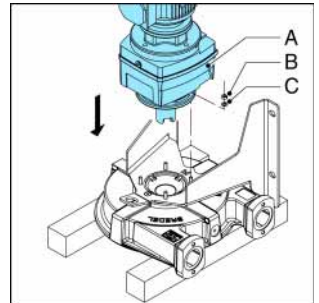

19. Put the hose pump upright on the support.

20. Check the position of the rotor. If necessary press the rotor on the hub until it clicks on the retaining ring.

21. Refit the cover (B). Make sure that the 4 bolts (A) are refitted and that they are tightened in the correct order, diagonally opposite each other. Refer to § 11.1.6.

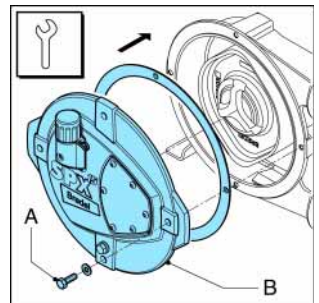

22. Switch on the electrical supply to the pump.

23. Fit the (new) pump hose. Refer to § 7.6.3.

7.8 Fitting options

7.8.1 Fitting a high-level float switch

1. Dismount the standard breather (A) on the cover of the pump head.

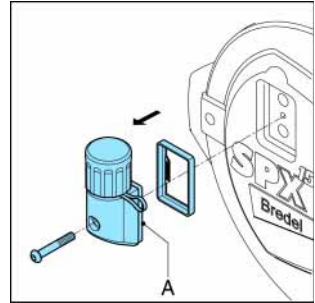

2. Mount the breather (A) with high-level float switch.

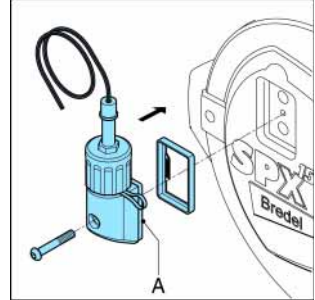

3. Connect the high-level float switch to the auxiliary power circuit via the 1.5 meter long PVC cable (2 x 0.24 mm²). Bear in mind that the electrical contact of the float switch is normally closed (NC). When the lubricant level is (too) high the contact will open.

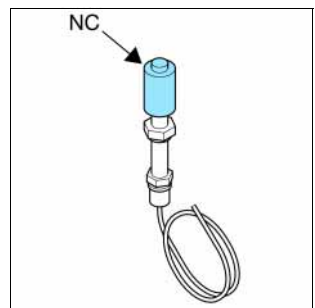

Specifications	
Voltage:	Max. 230 V AC/DC
Current:	Max. 1 A
Power:	Max. 50 W



Where the floater is constructed to stop the equipment, operating has to be arranged so that the stop function locks-out, preventing the equipment from being re-started without re-setting. Check if the floater is mounted with the NC sign at the top.

7.8.2 Revolution counter

For feedback of the pump revolutions to an "intelligent" system, the pump can be provided with an inductive sensor (A). This sensor is mounted between the two ports.

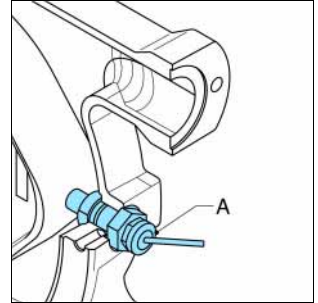

Connection of the revolution counter:

The speed sensor can be connected via the 2 meter long PVC cable (3 x 0.34 mm²).

Specifications	
Voltage:	10...30 VDC
Current:	Max. 200 mA

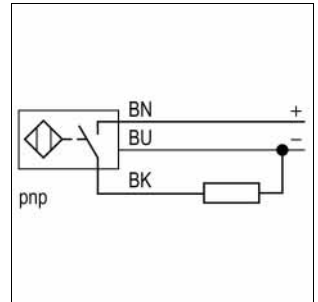

Adjustment sensor:

The sensor (A) must be adjusted at an offset of 1-2 mm to the rotor (B).

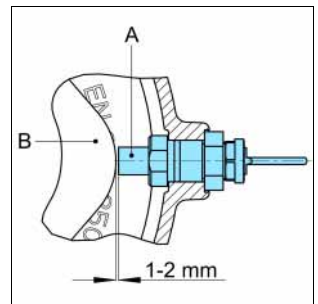

8 STORAGE

8.1 Hose pump

- Store the hose pump or pump parts in a dry area. Make sure that the hose pump or pump parts are not exposed to temperatures lower than -40 °C (-104 °F) or higher than $+70\text{ °C}$ ($+158\text{ °F}$).
- Cover the openings of the inlet and outlet ports.
- Prevent corrosion of untreated parts. For this purpose use the correct protection or packaging means.
- After a long period of standstill or storage, the static load on the pump hose may have caused permanent deformation, which will reduce the life of the pump hose. To prevent this, remove the pump hose.

8.2 Pump hose

- Store the pump hose in a cool and dark room. After 2 years the hose material will age, which will reduce the life of the hose.

9 TROUBLESHOOTING



WARNING

Disconnect and lock the power supply to the pump drive before any work is carried out.

Wait two minutes to make sure that the capacitors have discharged. This is necessary when the motor is fitted with a frequency controller and has single phase power supply.

If the hose pump does not function (correctly), consult the following checklist to see if you can remedy the error yourself. If this is not the case, contact your Watson-Marlow Bredel representative.

Problem	Possible cause	Correction
Failure to operate.	No voltage.	Check that the supply power switch is on.
		Check the electrical supply is available at the pump.
	Stalled rotor.	Check if the pump is stalled by incorrect fitting of the hose.
	Lubricant level monitoring system has been activated.	Check that the lubricant level monitoring system has stalled the pump. Check the functioning of the lubricant level monitoring system, or check the lubricant level.

Problem	Possible cause	Correction
High pump temperature.	Non standard hose lubricant used.	Consult the Watson-Marlow Bredel representative for the correct lubricant.
	Low lubricant level.	Add Watson-Marlow Bredel Genuine Hose Lubricant. For the required amount of lubricant refer to § 11.1.4.
	Product temperature too high.	Consult the Watson-Marlow Bredel representative about the maximum temperature range of the product.
	Internal friction on the hose caused by blocked or poor suction characteristics.	Check pipework/valves for blockages. Ensure that the suction pipework is as short as possible and that the diameter is large enough.
	High pump speed.	Reduce pump speed to a minimum. Consult with your Watson-Marlow Bredel pump representative for advice on optimum pump speeds.

Problem	Possible cause	Correction
<p>Low capacity / pressure.</p>	<p>Shut-off valve in the suction line (partly) closed.</p>	<p>Fully open the shut-off valve.</p>
	<p>Hose rupture or badly worn hose.</p>	<p>Replace hose. Refer to § 7.6.</p>
	<p>(Partial) blockage of the suction line or too little product on the suction side.</p>	<p>Ensure that the suction line is clear of blockages and that sufficient product is available.</p>
	<p>Connections and hose clamps not correctly mounted, which makes the pump suck air.</p>	<p>Tighten connections and hose clamps.</p>
	<p>The filling degree of the pump hose is too low, because the speed is too high in relation to the viscosity of the product to be pumped and the inlet pressure. The suction line can be too long or too narrow or a combination of these factors.</p>	<p>Consult your Watson-Marlow Bredel representative for a recommendation.</p>

Problem	Possible cause	Correction
Vibration of the pump and pipework.	Suction and discharge lines are not secured correctly.	Check and secure pipe-work.
	High pump speed with long suction and discharge lines or high relative density or a combination of these factors.	Reduce pump speed. Reduce the line lengths on both suction and discharge where possible. Consult your Watson-Marlow Bredel representative for a recommendation.
	Too narrow diameter of suction and/or discharge line.	Increase the diameter of the suction/discharge lines.
Short hose life.	Chemical attack of the hose.	Check the compatibility of the hose material with the product to be pumped. Consult your Watson-Marlow Bredel representative for correct hose selection.
	High pump speed.	Reduce pump speed.
	High discharge pressures.	Maximum working pressure 750 kPa (109 psi). Check that the discharge line is not blocked, the shut-off valves are fully opened and the pressure relief valve functions properly (if present in the discharge line).
	High product temperature.	Consult your Watson-Marlow Bredel representative for correct hose selection.
	High pulsations.	Restructure the discharge and inlet conditions.

Problem	Possible cause	Correction
Hose pulled into the pump.	Insufficient or no hose lubricant in the pump head.	Add extra lubricant. Refer to § 7.5.
	Incorrect lubricant: no Watson-Marlow Bredel Genuine Hose Lubricant in the pump head.	Consult the Watson-Marlow Bredel representative for the correct lubricant.
	Extremely high inlet pressure - larger than 300 kPa (43.5 psi).	Reduce the inlet pressure.
Lubricant leakage at bracket.	Hose blocked by an incompressible object in the hose. The hose cannot be compressed and will be pulled into the pump housing.	Remove hose, check for blockages and replace if necessary.
	Bolts of bracket loose.	Tighten to the specified torque settings. Refer to § 11.1.6.
	Bolts of hose clamps loose.	Tighten to the specified torque settings. Refer to § 11.1.6.
Leakage from the rear of the pump housing "Buffer zone".	Damaged seal ring.	Replace seal ring.

10 HAZARDOUS ENVIRONMENTS (ATEX)

10.1 ATEX compliance

Hose pumps that are configured for use in potentially explosive environments comply to CE directive 94/9/EC (ATEX directive). The hose pumps as mentioned on the front cover comply to: Group II Appliances, category 2 GD. Refer to § 10.2.1 for a more detailed definition.

10.2 Identification

10.2.1 Pump head

Hose pumps that are configured for use in potentially explosive environments are identified by an extra ATEX plate on the rear of the pump head on one of the ports. The plate contains the following data:

- A ATEX code
- B ATEX document number
- C year of manufacture

The following table explains the ATEX code on the ATEX plate.

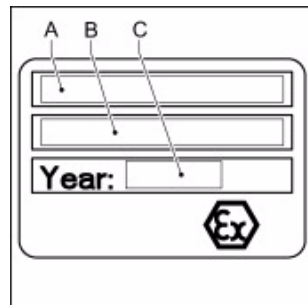

II	Group II equipment for use in potentially explosive atmospheres, other than mines susceptible to firedamp.
2	Category 2 equipment for the requisite level of protection, even if frequently occurring disturbances or equipment faults have to be taken into account.
G	Equipment for use in explosive atmospheres caused by gases, vapours or mists.
D	Equipment for use in explosive atmospheres caused by dusts.
k	Equipment protected by liquid immersion.
c	Equipment protected by constructional safety.
b	Equipment protected by control of ignition source.

T5	Classification for Group II G equipment concerning the maximum surface temperature.
T90°C	Maximum surface temperature for Group II D equipment, according to thermal test (EN 13463).

10.2.2 Gearbox

The gearbox must be selected to meet your requirements concerning ATEX. Please contact your Watson-Marlow Bredel representative.

10.2.3 Electric motor

The electric motor must be selected to meet your requirements concerning ATEX. Please contact your Watson-Marlow Bredel representative.

10.2.4 Frequency controller

The frequency controller must be selected to meet your requirements concerning ATEX. Please contact your Watson-Marlow Bredel representative.

11 SPECIFICATIONS

11.1 Pump head

11.1.1 Performance

Description		Unit	SPX10	SPX15	SPX20
Max. capacity, continuous		m ³ /h	0.11	0.38	0.62
		gpm	0.48	1.67	2.7
Max. capacity, intermittently *		m ³ /h	0.16	0.60	1.09
		gpm	0.70	2.6	4.8
Capacity per revolution		l/rev	0.022	0.083	0.152
		gal/rev	0.0058	0.022	0.040
Max. permissible working pressure	with low-pressure rotor	kPa	400	400	400
		psi	58	58	58
	with high-pressure rotor	kPa	750	750	750
		psi	109	109	109
Permissible ambient temperature		°C	-20 to +45		
		°F	-4 to +113		
Permissible product temperature		°C	-10 to +80		
		°F	+14 to +176		
Sound level at 1 m (3.3 ft)		dB(A)	60		

* Intermittent duty: "Let the pump stand still to cool down for at least 1 hour after 2 hours of operation".

11.1.2 Materials

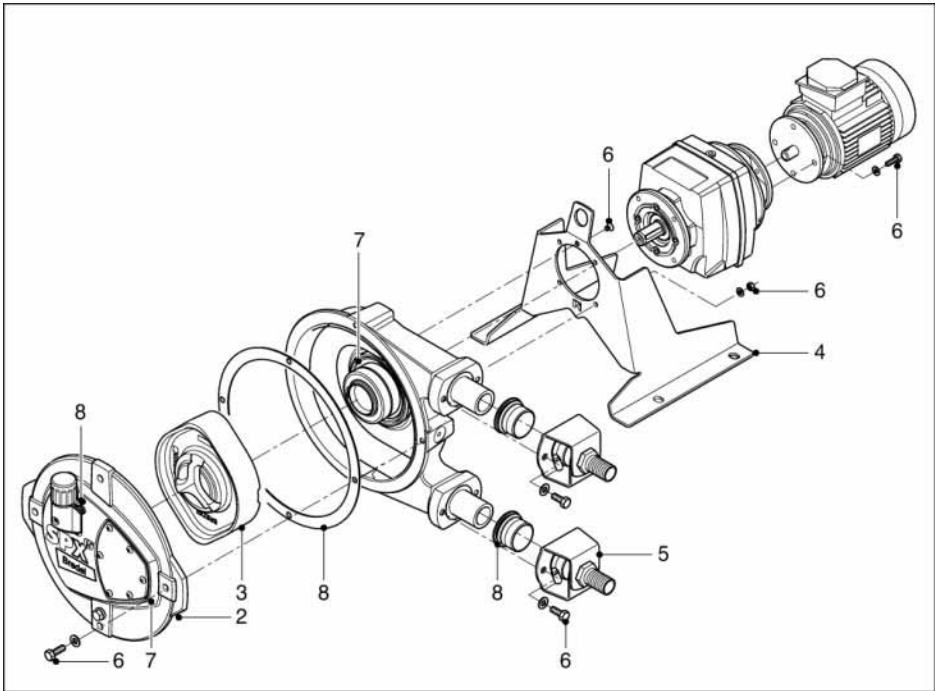

Pos	Description	Material
1	Pump housing	Cast-iron
2	Cover	Cast-iron
3	Pump rotor	Cast-iron
4	Pump support	Galvanized steel (AISI 316 optional)
5	Bracket	AISI 316
6	Fasteners	AISI 316
7	Seals, gaskets	NBR
8	Seals, gaskets	EPDM

11.1.3 Surface treatment

- After surface preparation, one layer of two-component acrylate is used for surface protection. Standard color is RAL 3011, however other colors are optional. Contact your Watson-Marlow Bredel representative for details on surface treatment.
- All galvanized parts, exclusive of mounting articles, have been provided with an electrolytic zinc layer of 15 - 20 microns.

11.1.4 Lubricant table pump

	Unit	SPX10	SPX15, SPX20
Lubricant	-	Watson-Marlow Bredel Genuine Hose Lubricant	Watson-Marlow Bredel Genuine Hose Lubricant
Required quantity	l	0.25	0.5
	gal	0.066	0.13

Watson-Marlow Bredel Genuine Hose Lubricant is registered at NSF: NSF Registration N° 123204; Category Code H1. See also: www.NSF.org/USDA.

	Should you require additional information with respect to the safety data sheet, consult your Watson-Marlow Bredel representative.
---	--

11.1.5 Weights

Description	Unit	Weight	
		SPX10	SPX15, SPX20
Pump head (inclusive of hose, lubricant and pump support)	kg	12.2	18.5
	lbs	26.9	40.8
Pump support	kg	1.8	2.4
	lbs	4.0	5.3
Hose	kg	0.4	0.8
	lbs	0.9	1.8
Lubricant	kg	0.3	0.6
	lbs	0.7	1.3
Pump cover (complete)	kg	2.3	6.0

Description		Unit	Weight	
			SPX10	SPX15, SPX20
		lbs	5.1	13.2
Coupling		kg	0.4	0.4
		lbs	0.9	0.9
Gearbox	G052...	kg	9.5	9.0
		lbs	20.9	19.8
	G053...	kg	10	10
		lbs	22	22
Electric motor		kg	4.5	6.5
		lbs	9.9	14.3

11.1.6 Torque figures

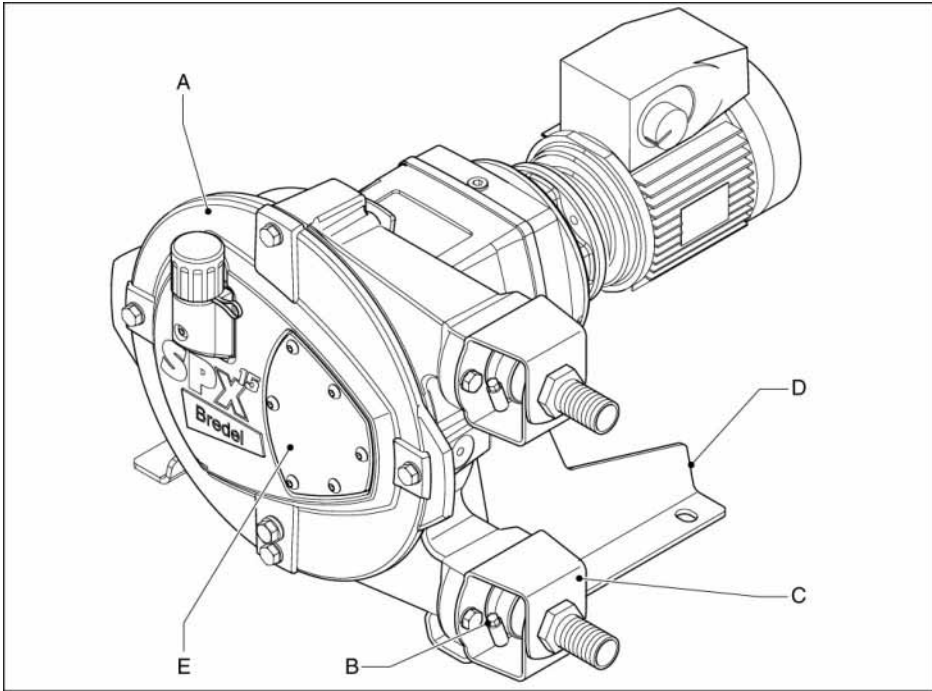

Pos	Description	Unit	Torques	
			SPX10	SPX15, SPX20
A	Cover	Nm	10	25
		lbf in	88.5	221
B	Hose clamp	Nm	3	3
		lbf in	26.5	26.5
C	Bracket	Nm	10	25
		lbf in	88.5	221
D	Support	Nm	10	10
		lbf in	88.5	88.5
E	Inspection window	Nm	1.5	1.5
		lbf in	13	13

11.2 Gearbox

Type	Co-axial gearbox with helical gears
Number of stages	Two or three
Lubrication	Lubricated for life
Mounting position	IM 2001 (IM B5) flanged gearbox with keyed shaft in horizontal position.
Motor adapter	Adapter in conformance with IEC-B5.
Optional motor adapter	Adapter in conformance with NEMA C.

11.3 Electric motor

Standard electric motor design is an enclosed three-phase asynchronous motor. A thermal safety device to prevent motor overload is optional.

Protection class	IP55/IK08
Insulation class	F
Increase in temperature	Within class B
Voltage/frequency	230/400 V - 3 phases - 50 Hz

	In case of doubt about the local applicable regulations for the drive connection, contact your Watson-Marlow Bredel representative.
---	---

11.4 Watson-Marlow Bredel Variable Frequency Drive (VFD) (optional)

The Watson-Marlow Bredel Variable Frequency Drive (VFD) has been preprogrammed and only needs to be connected to the mains.

RFI filter	Integrated RFI filter B (industrial applications).
Control	Manual control for setting the speed and the keys for starting forward, stop and starting reverse.

Protection class	IP65
Mains power supply	<p>There are 3 types available; the choice depends on the local electricity grid:</p> <ul style="list-style-type: none"> ● 200-240 V ± 10%; 50/60 Hz ± 5%; 1 ph ● 200-240 V ± 10%; 50/60 Hz ± 5%; 3 ph ● 400-480 V ± 10%; 50/60 Hz ± 5%; 3 ph

11.5 Parts list

11.5.1 Overview

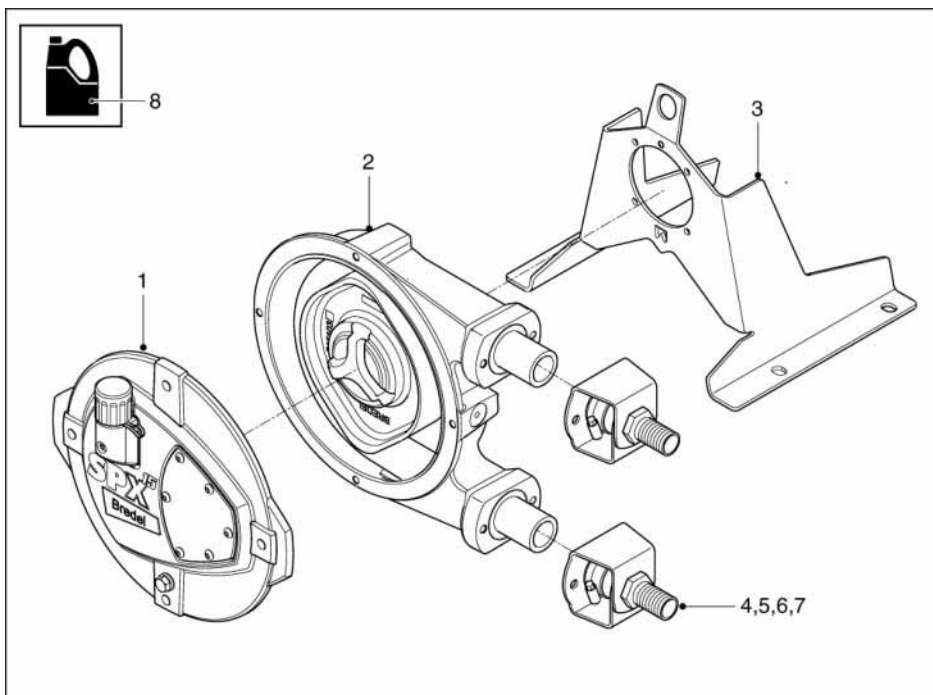

Pos.	Description
1	Cover assembly. Refer to § 11.5.2.
2	Pump head assembly. Refer to § 11.5.3.
3	Pump support assembly. Refer to § 11.5.4.
4	Hose nipple assembly. Refer to § 11.5.5.
5	Threaded nipple assembly. Refer to § 11.5.6.

Pos.	Description
6	Flange assembly (1). Refer to § 11.5.7.
7	Flange assembly (2). Refer to § 11.5.8.
8	Lubricants. Refer to § 11.5.10.

11.5.2 Cover assembly

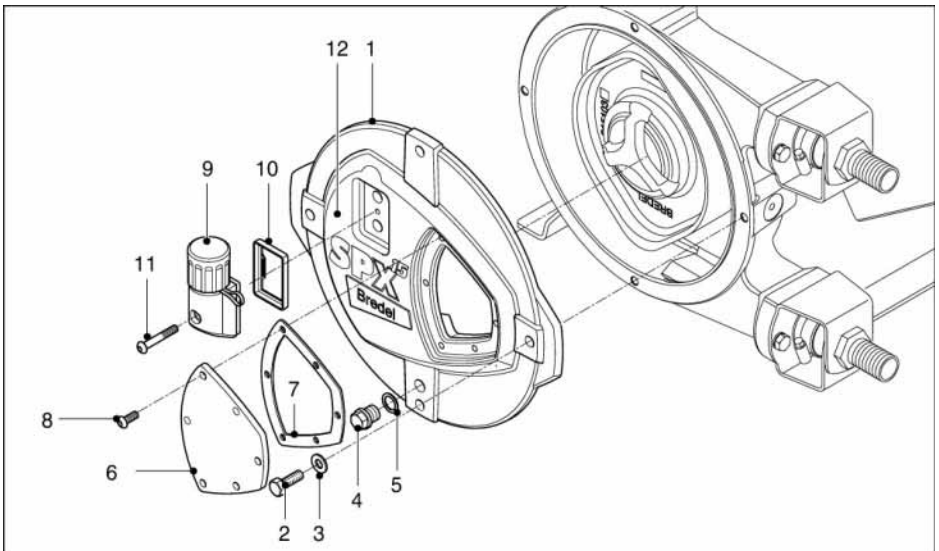

Pos.	Qty	Description	SPX10	SPX15	SPX20
1	1	Cover	210102	215102	215102
2	2	Bolt, hex. head	F504038	-	-
	4		-	F504055	F504055
3	2	Washer	F523010	-	-
	4		-	F523012	F523012
4	1	Drain plug	F911502	F911502	F911502
5	1	Gasket	F342019	F342019	F342019
6	1	Inspection window	210155	215155	215155
7	1	Gasket	210156	215156	215156
8	3	Round head screw	F552535	-	-
	6		-	F552535	F552535
9	1	Breather	29093146	29093146	29093146

Pos.	Qty	Description	SPX10	SPX15	SPX20
10	1	Gasket	29056334	29056334	29056334
11	1	Round head screw	F552541	F552541	F552541
12	1	Sticker	210238	215238	215238

11.5.3 Pump head assembly

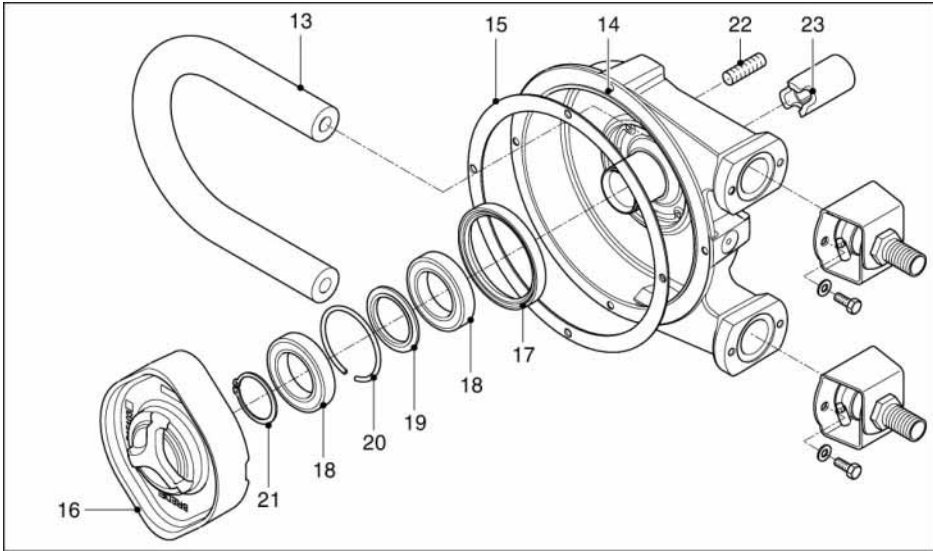

Pos.	Qty	Description	SPX10	SPX15	SPX20
13	1	Hose NR	010020	015020	020020
	1	Hose NBR	010040	015040	020040
	1	Hose EPDM	010075	015075	020075
14	1	Pump housing	210101	215101	215101
15	1	Gasket	210123	215123	215123
16	1	Rotor, low pressure (L)	210103L	215103L	220103L
		Rotor, high pressure (H)	210103H	215103H	220103H
17	1	Seal ring	S211811	S211811	S211811
18	2	Bearing	B141060	B141060	B141060
19	1	Spacer ring	29070201	29070201	29070201
20	1	Retaining ring	29080297	29080297	29080297
21	1	Circlip	F343043	F343043	F343043

Pos.	Qty	Description	SPX10	SPX15	SPX20
22	4	Stud	F511001	F511001	F511001
23	1	Coupling, \varnothing 0.8 x 2.5 in	29063255	29063255	29063255
		Coupling, \varnothing 0.8 x 2.7 in	29068255	29068255	29068255
		Coupling, \varnothing 1.0 x 2.5 in	29064255	29064255	29064255
		Coupling, \varnothing 1.0 x 2.7 in	29069255	29069255	29069255

11.5.4 Support assembly

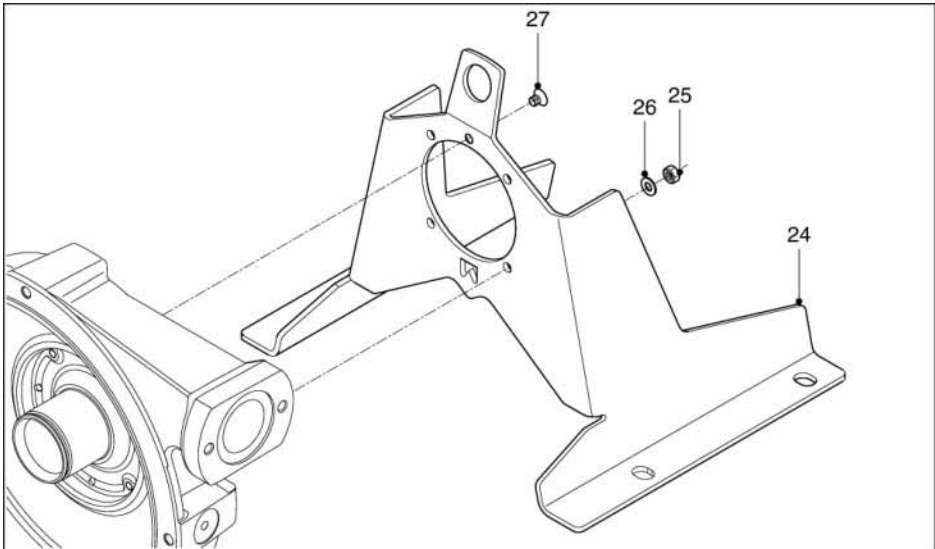

Pos.	Qty	Description	SPX10	SPX15	SPX20
24	1	Pump support	210106	215106	215106
25	4	Nut, hex. head	F516010	F516010	F516010
26	4	Washer	F532008	F532008	F532008
27	1	Screw, countersunk head	F507040	F507040	F507040

11.5.5 Hose nipple assembly (PTFE/PVDF)

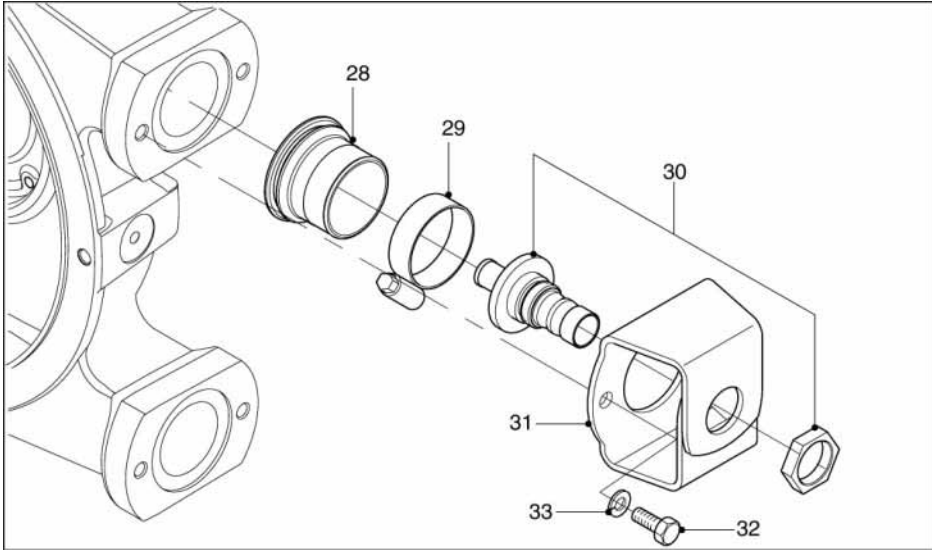

Pos.	Qty	Description	SPX10	SPX15	SPX20
28	2	Rubber bush	210119	215119	215119
29	2	Hose clamp	C112506	C112508	C112508
30	2	Hose nipple PTFE	210688010	215688015	215688020
		Hose nipple PVDF	210690010	215690015	215690020
31	2	Bracket	210197	215197	215197
32	4	Bolt, Hex. head	F504036	F504054	F504054
33	4	Washer	F532008	F532009	F532009

11.5.6 Hose or threaded nipple assembly (AISI 316)

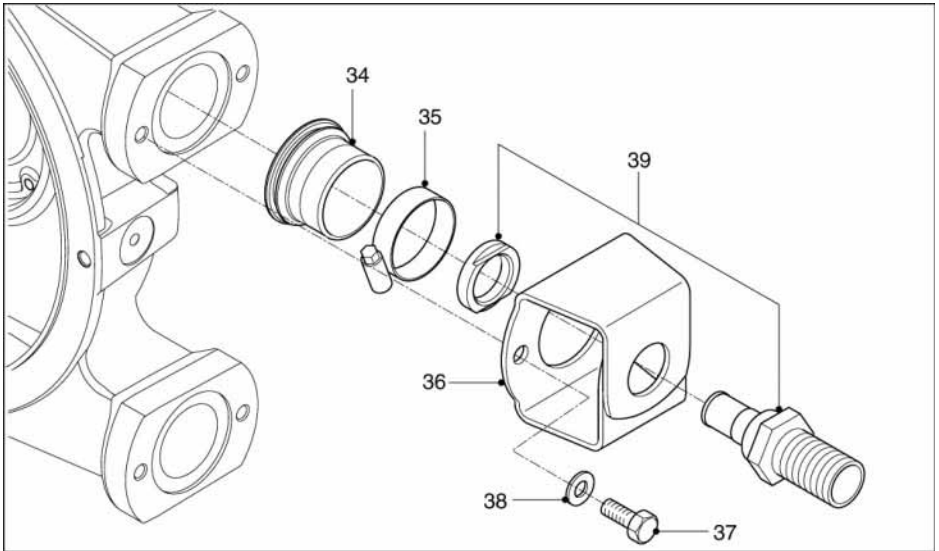

Pos.	Qty	Description	SPX10	SPX15	SPX20
34	2	Rubber bush	210119	215119	215119
35	2	Hose clamp	C112506	C112508	C112508
36	2	Bracket	210197	215197	215197
37	4	Bolt, Hex. head	F504036	F504054	F504054
38	4	Washer	F532008	F532009	F532009
39	2	Threaded nipple (BSP) SS	210693010	215693015	215693020
		Hose nipple SS	210686010	215686015	215686020
		Threaded nipple DIN 11851 SS	210702010	215702015	215702020
		Threaded nipple (NPT) PP	210696010	215696015	215696020
		Threaded nipple (NPT) PVC	210697010	215697015	215697020
		Threaded nipple (NPT) SS	210698010	215698015	215698020

11.5.7 Flange assembly (1)

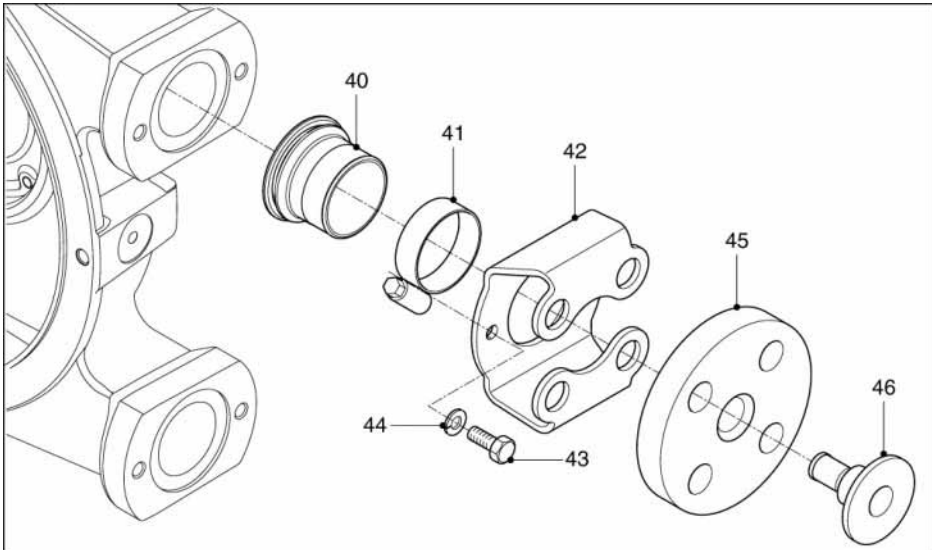

Pos.	Qty	Description	SPX10	SPX15	SPX20
40	2	Rubber bush	210119	215119	215119
41	2	Hose clamp	C112506	C112508	C112508
42	2	Flange bracket	210197A	215197A	215197A
43	4	Bolt, Hex. head	F504036	F504054	F504054
44	4	Washer	F532008	F532009	F532009
45	2	Flange ASA	210199A	215199A	215199A
46	2	Insert PP	210189	215189	220189

11.5.8 Flange assembly (2)

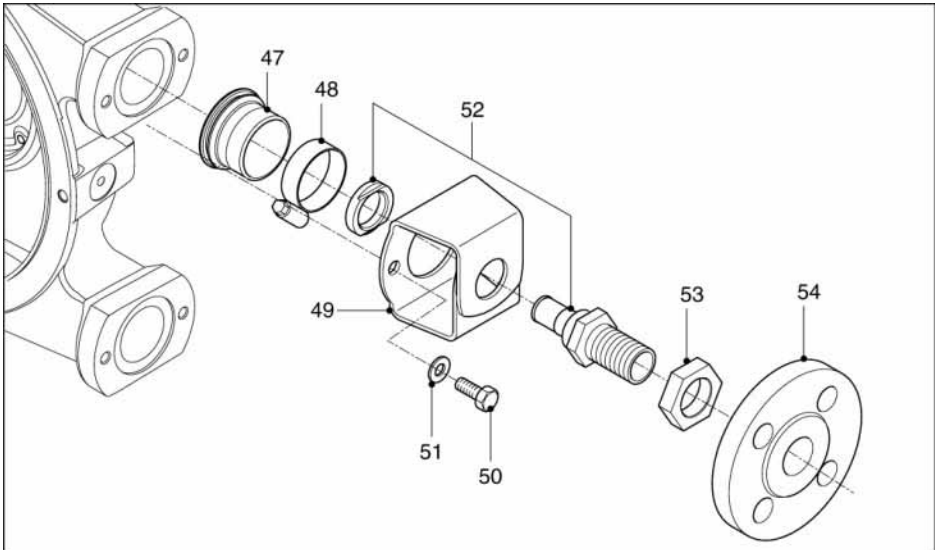

Pos.	Qty	Description	SPX10	SPX15	SPX20
47	2	Rubber bush	210119	215119	215119
48	2	Hose clamp	C112506	C112508	C112508
49	2	Bracket	210197	215197	215197
50	4	Bolt, Hex. head	F504036	F504054	F504054
51	4	Washer	F532008	F532009	F532009
52	2	Threaded nipple (BSP) SS	210693010	215693015	215693020
53	2	Nut	F519003	F519004	F519004
54	2	Flange DIN SS	A304504	A304505	A304505
	2	Flange ASA SS	A305504	A305505	A305505

11.5.9 Revolution counter assembly

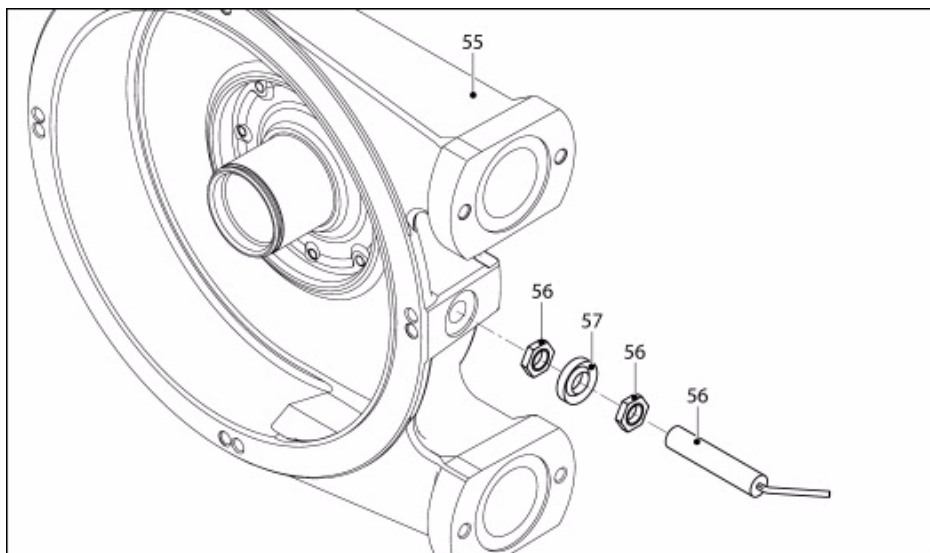

Pos.	Qty	Description	SPX10	SPX15	SPX20
55	1	Pump housing	210101A	215101A	215101A
56	1	Revolution counter	29060367	29060367	29060367
57	1	Gasket ring	F724009	F724009	F724009

11.5.10 Lubricants

Pos.	Qty	Description	SPX10	SPX15	SPX20
58	1	0.5 l (0.13 gal) can Watson-Marlow Bredel Genuine Hose Lubricant	901143	901143	901143

Watson-Marlow Pumps Group
37 Upton Technology Park
Wilmington, MA 01887
USA

Telephone: 800 - 282 - 8823
978 - 658 - 6168

Fax: 978 - 658 - 0041

Internet: www.wmpg.com

E-mail: support@wmpg.us



© 2010 Watson-Marlow Bredel B.V.