

1	2	3	4	5	6	7	8
Overview					1100_Overview.vsd	Function diagram	
General Overview					06.07.2001 V1.13	MICROMASTER 420	

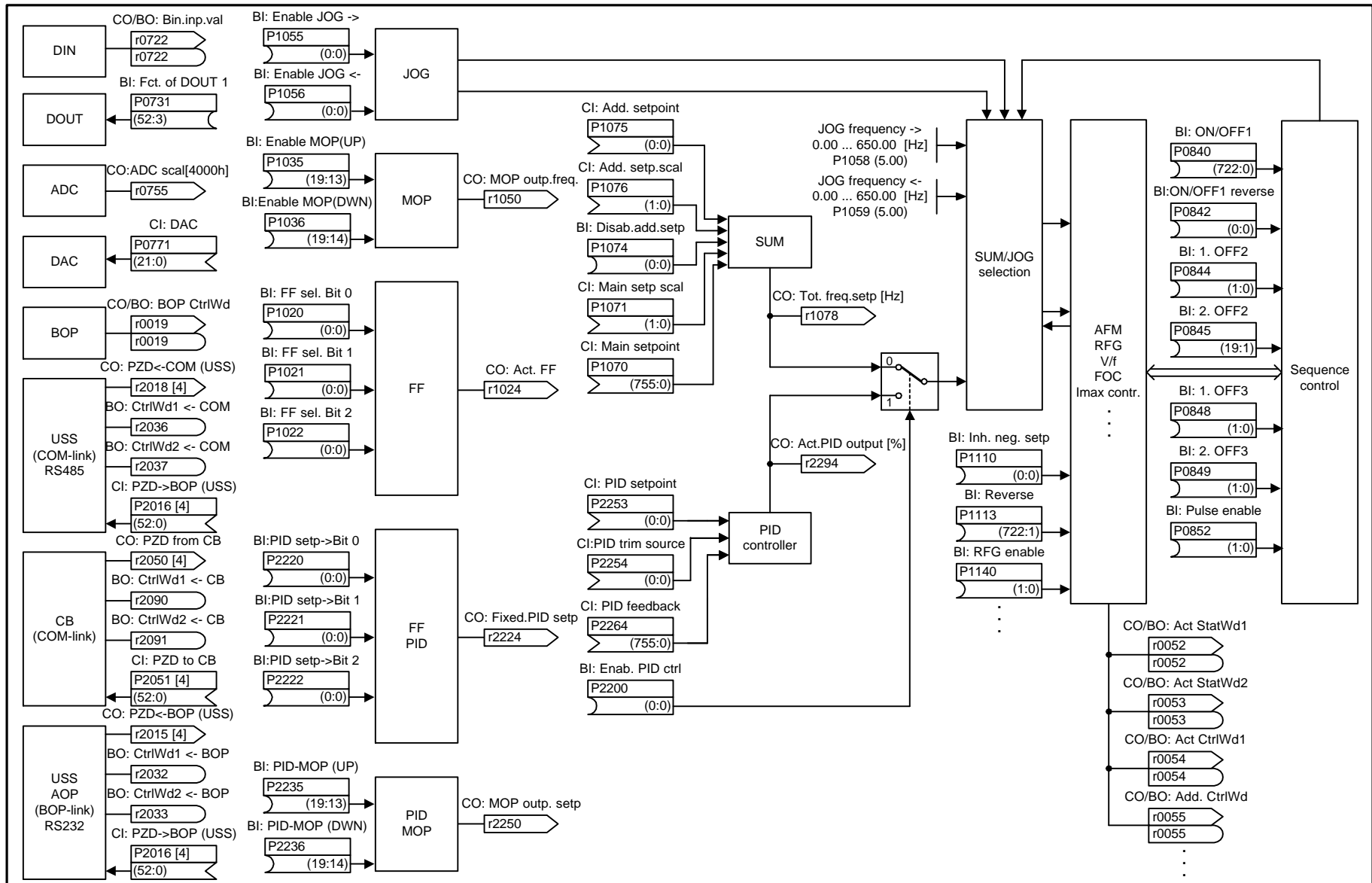

Overview

1200_BICO_Overv.vsd

Function diagram

Connection of External and Internal Setpoints

20.07.2001 V1.13

MICROMASTER 420

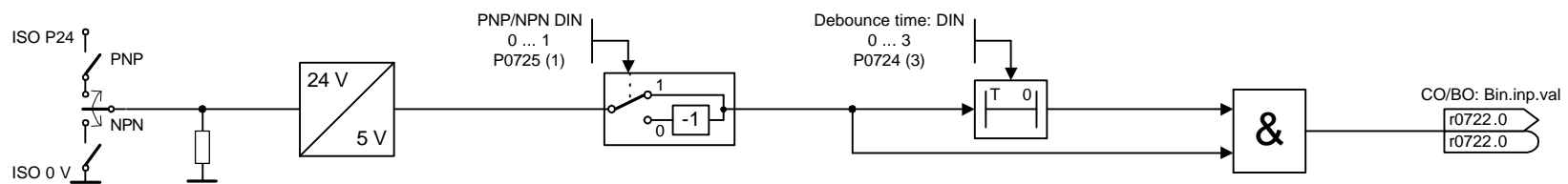

1	2	3	4	5	6	7	8
External Command + Setpoint Source					2000_DIN.vsd	Function diagram	
Digital Inputs					06.07.2001 V1.13	MICROMASTER 420	
- 2000 -							

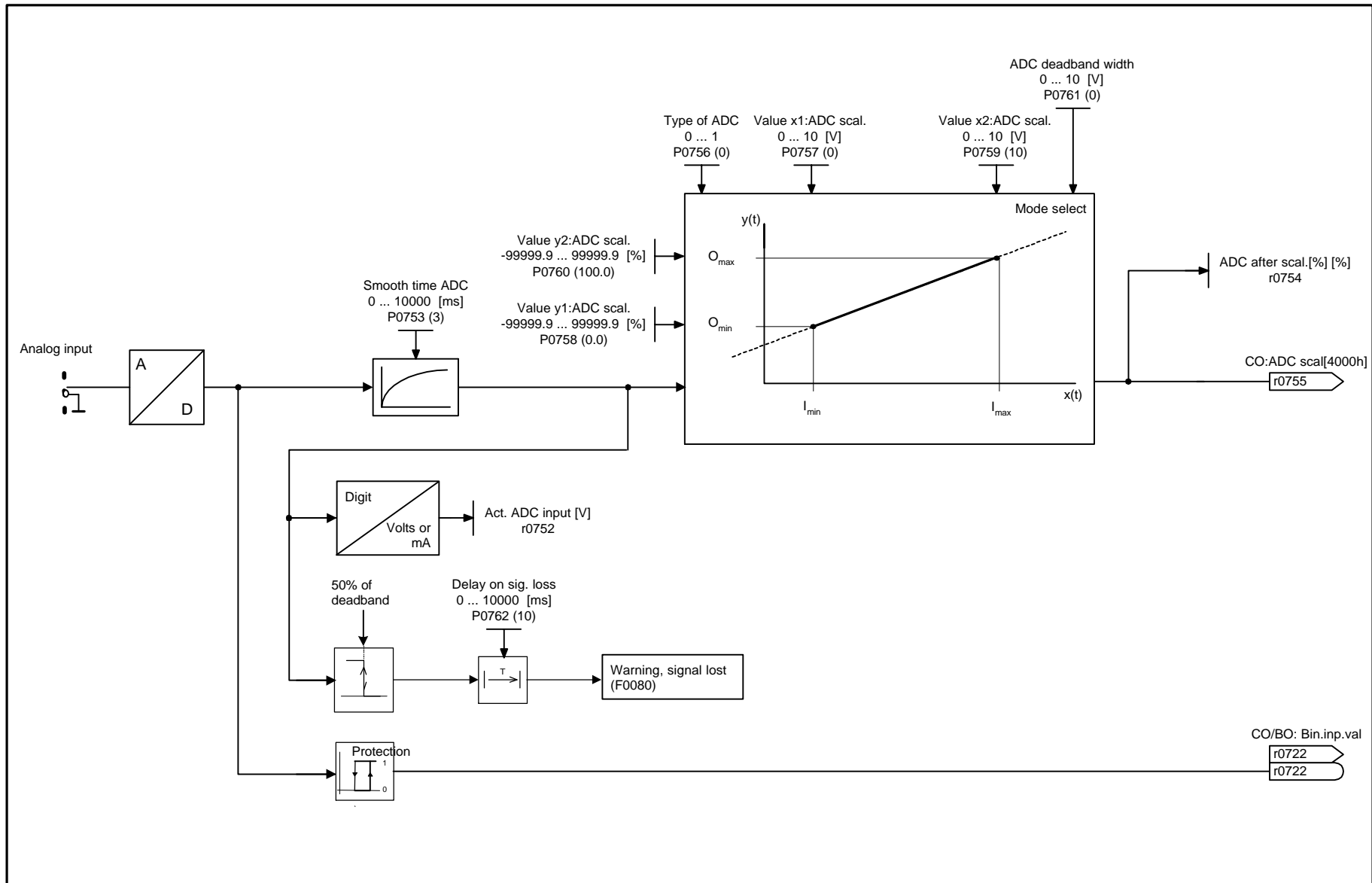

1	2	3	4	5	6	7	8
External Command + Setpoint Source					2200_ADC.vsd	Function diagram	
Analog Input (ADC)					06.07.2001 V1.13	MICROMASTER 420	
							- 2200 -

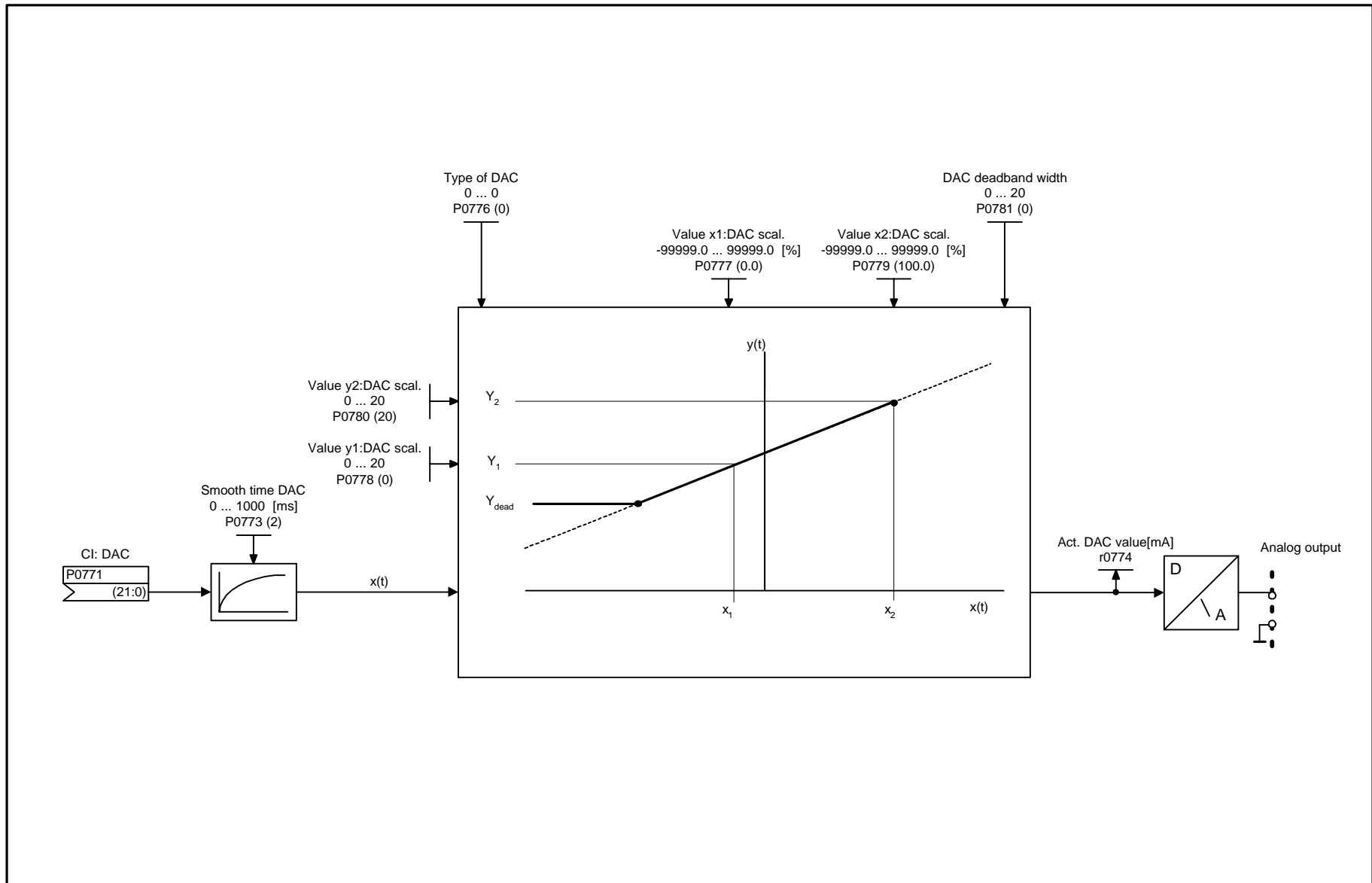

1	2	3	4	5	6	7	8
External Command + Setpoint Source					2300_DAC.vsd	Function diagram	
Analog Output (DAC)					06.07.2001 V1.13	MICROMASTER 420	
- 2300 -							

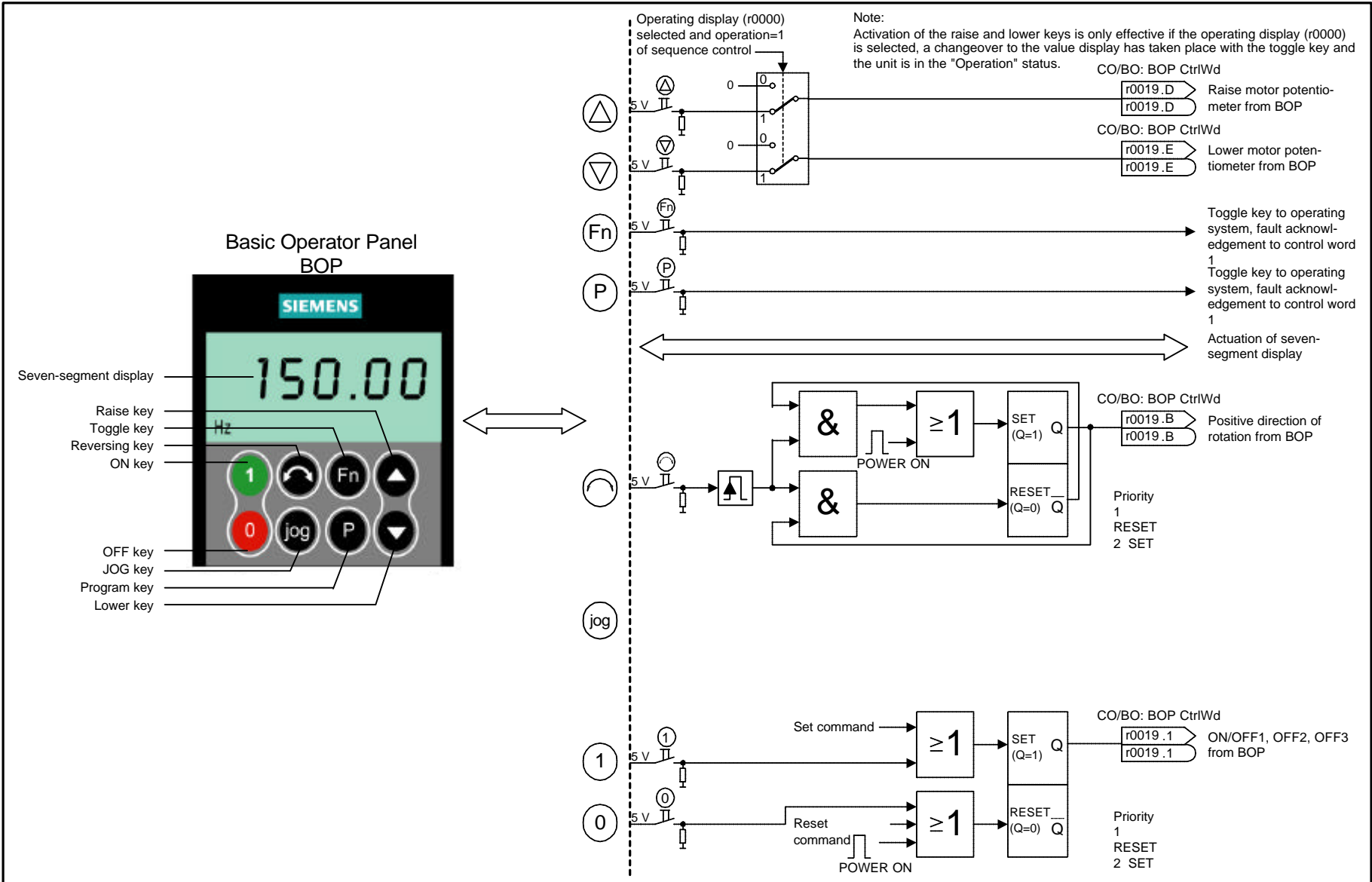

1	2	3	4	5	6	7	8
External Command + Setpoint Source					2400_BOP.vsd	Function diagram	
Basic Operator Panel (BOP)					06.07.2001 V1.13	MICROMASTER 420	

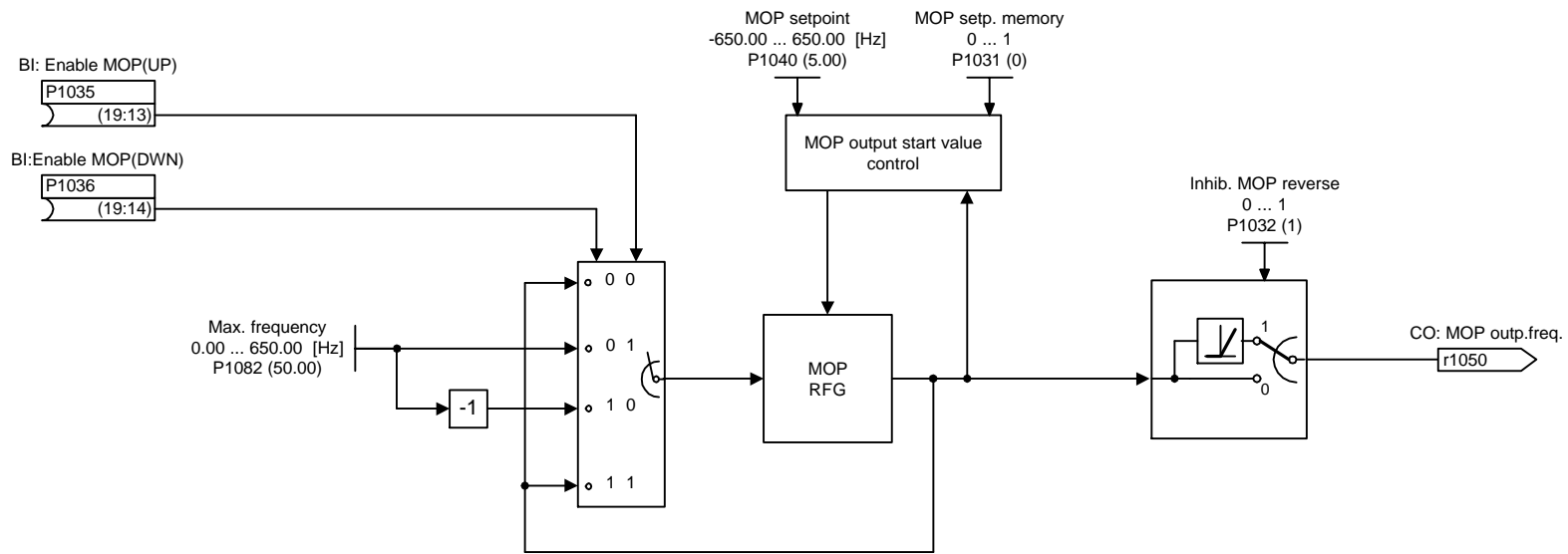

1	2	3	4	5	6	7	8
Internal Setpoint Source					3100_MOP.vsd	Function diagram	
Motor Potentiometer (MOP)					06.07.2001 V1.13	MICROMASTER 420	

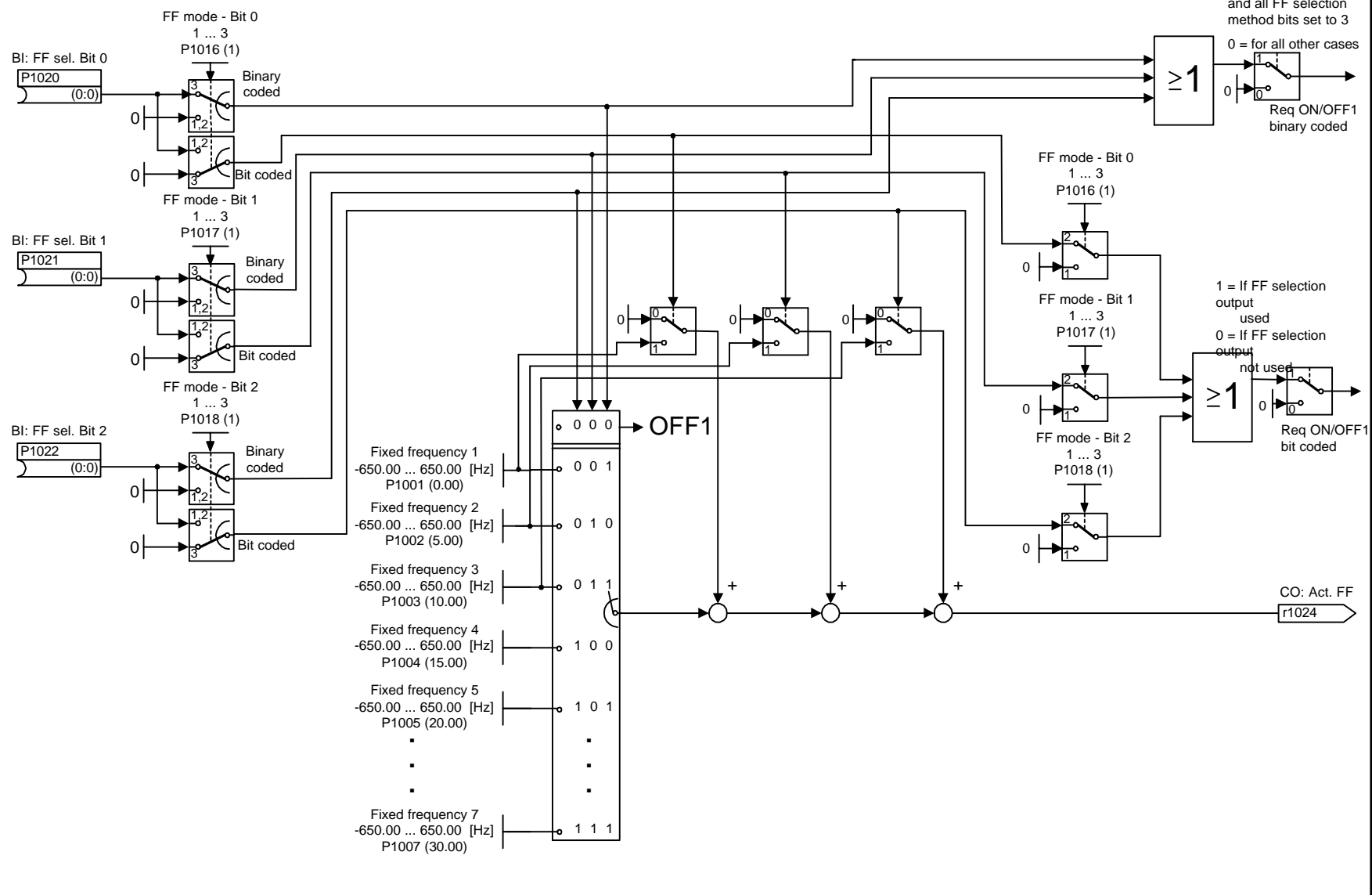

1	2	3	4	5	6	7	8
Internal Setpoint Source					3200_FF.vsd	Function diagram	
Fixed Frequency (FF)					06.07.2001 V1.13	MICROMASTER 420	
- 3200 -							

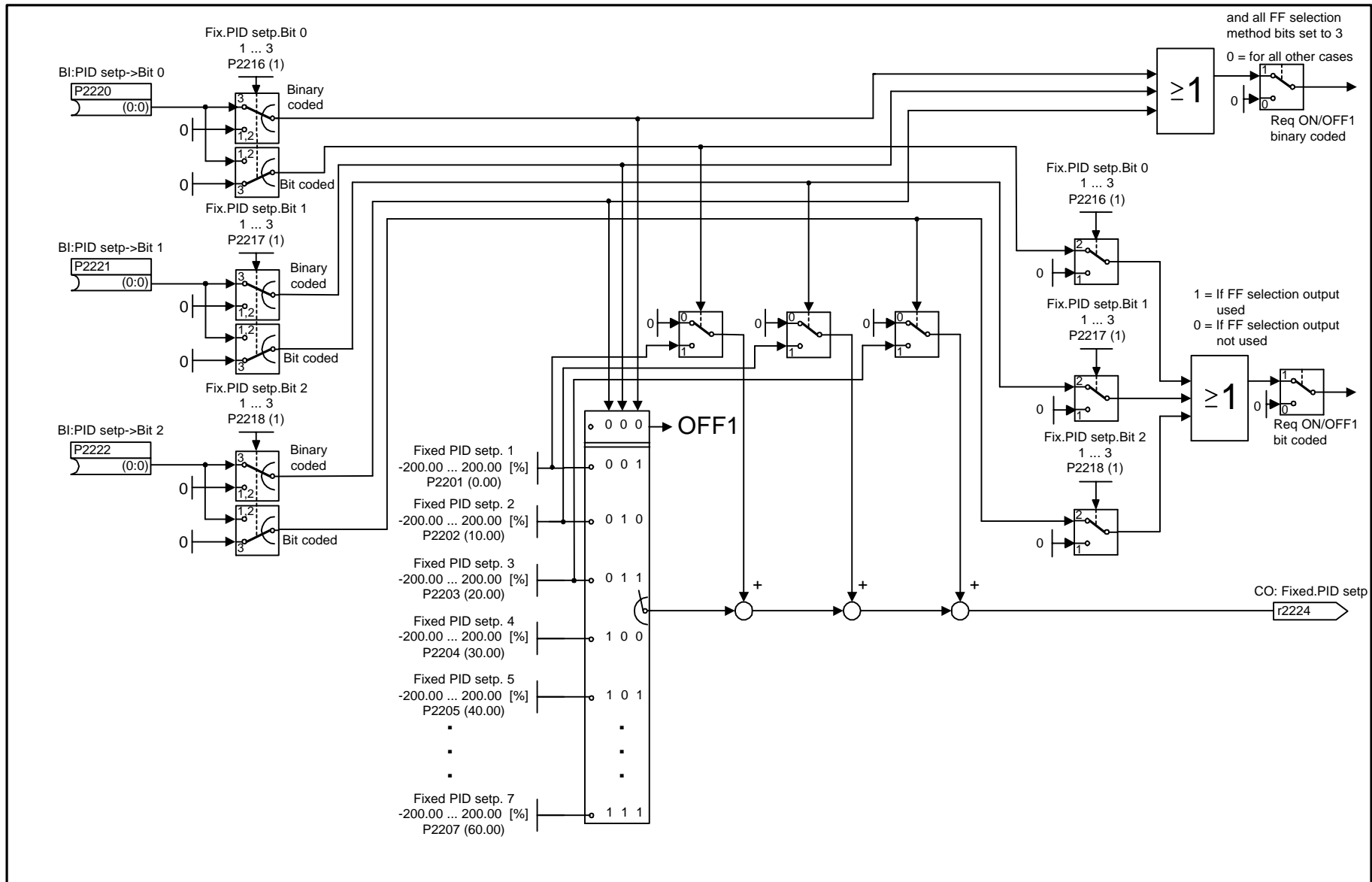

1	2	3	4	5	6	7	8
Internal Setpoint Source					3300_FPID.vsd	Function diagram	
Fixed PID setpoint					06.07.2001 V1.13	MICROMASTER 420	
- 3300 -							

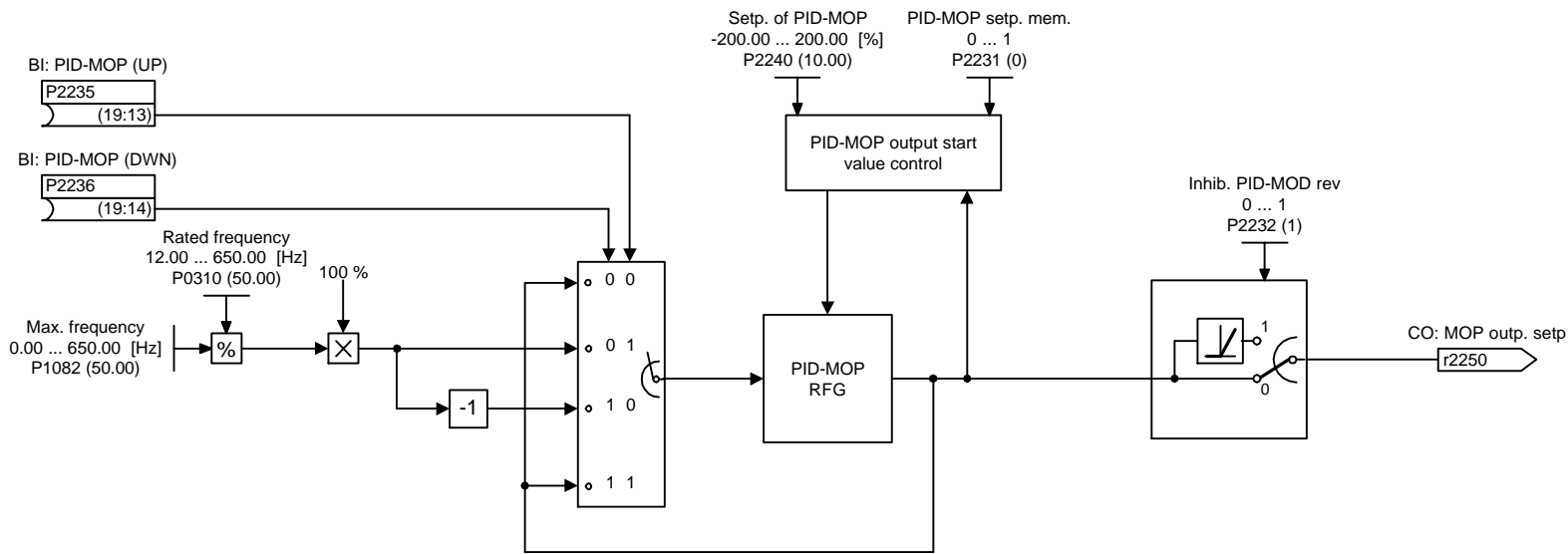

1	2	3	4	5	6	7	8
Internal Setpoint Source					3400_PIDMOP.vsd	Function diagram	
PID Motor Potentiometer (PID-MOP)					06.07.2001 V1.13	MICROMASTER 420	

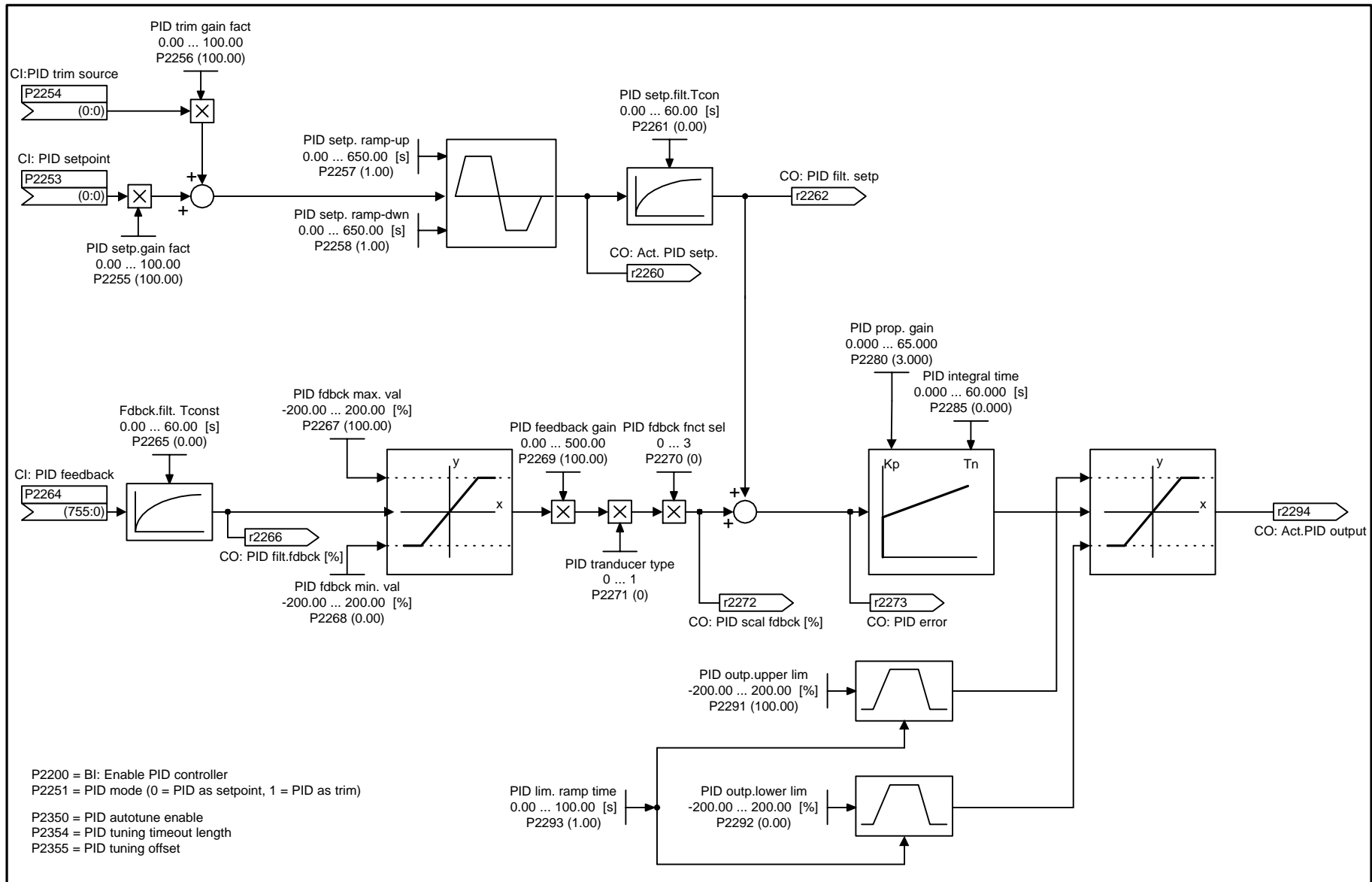

1	2	3	4	5	6	7	8
Technology Functions					4400_PID.vsd	Function diagram	
PID controller					06.07.2001 V1.13	MICROMASTER 420	
- 4400 -							

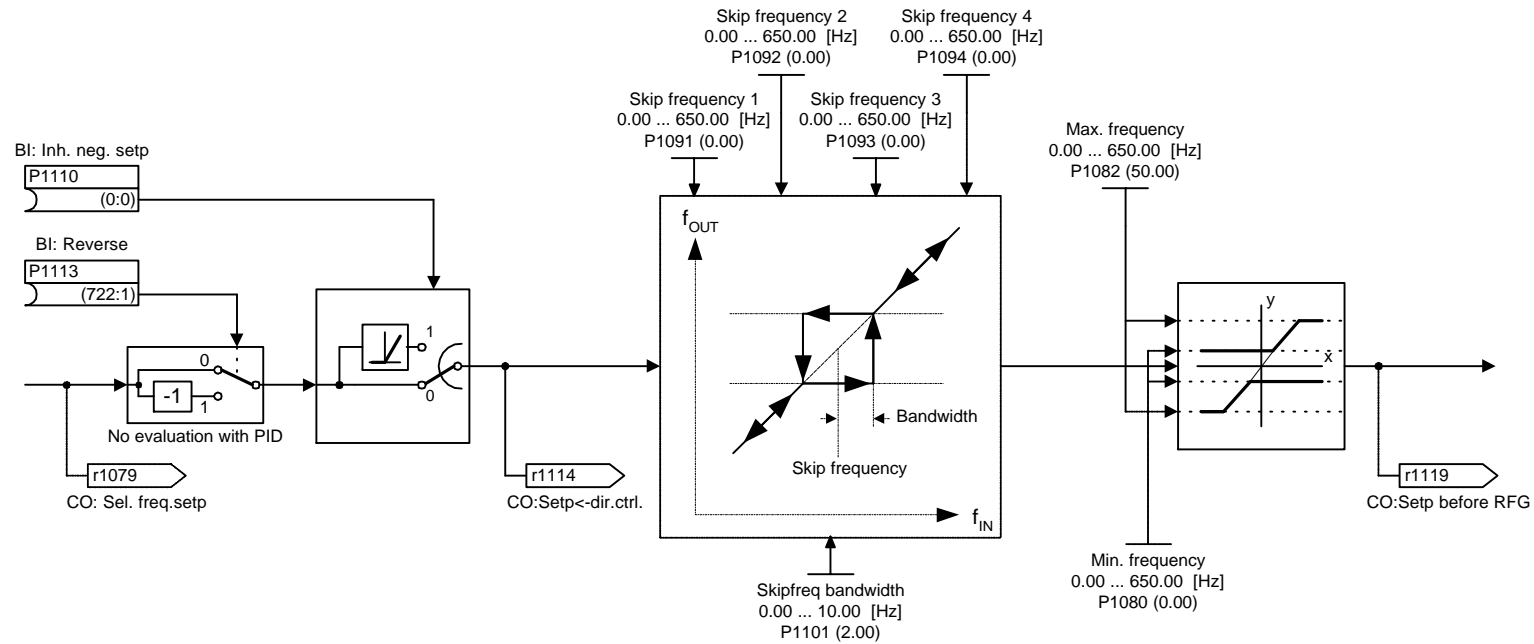

1	2	3	4	5	6	7	8
Setpoint channel					5200_AFM.vsd	Function diagram	
Additional Frequency Modifications (AFM)					06.07.2001 V1.13	MICROMASTER 420	
- 5200 -							

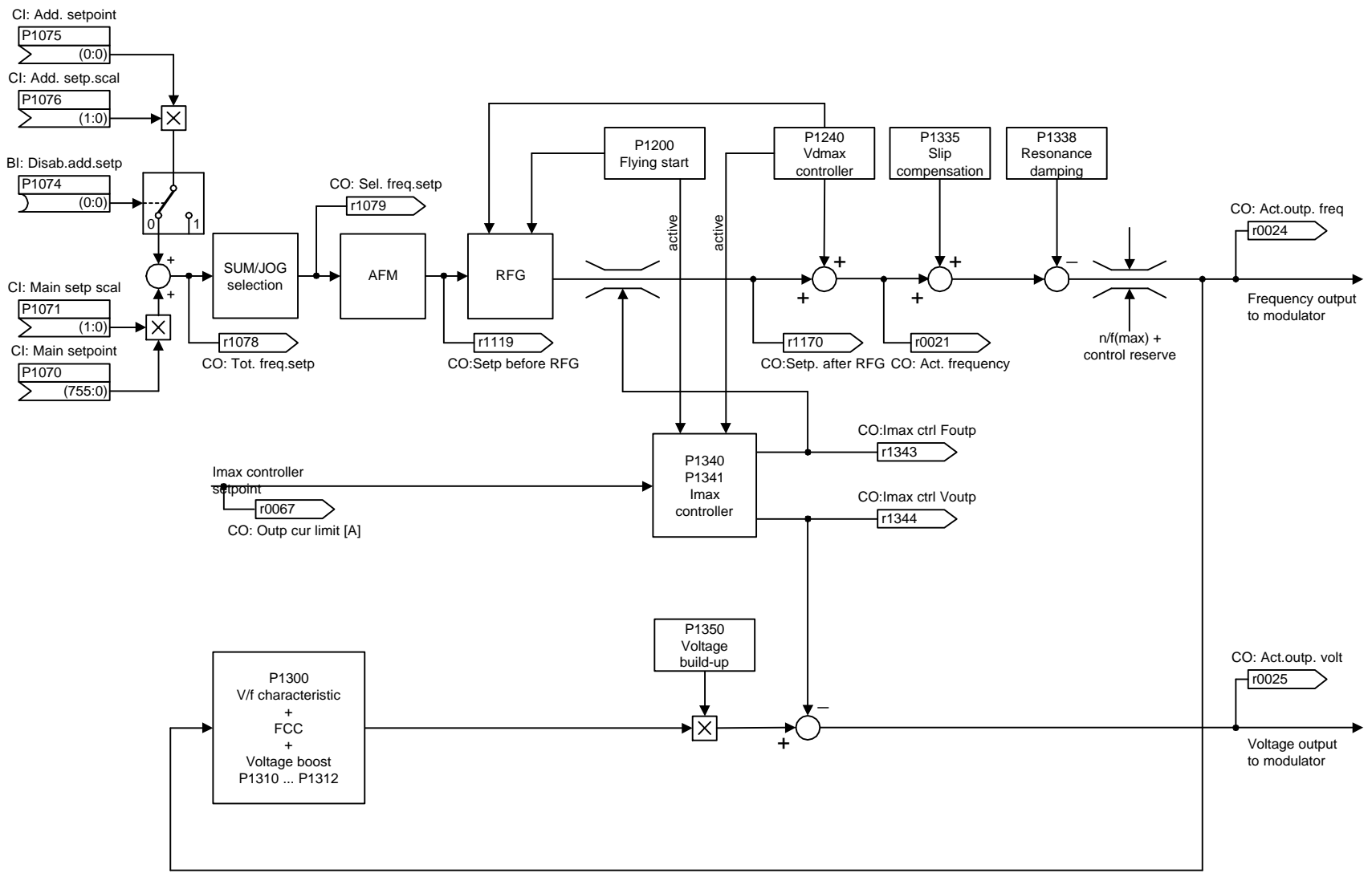

1	2	3	4	5	6	7	8	
Control					6100_V_f.vsd		Function diagram	- 6100 -
Overview of V/f Control					06.07.2001 V1.13		MICROMASTER 420	

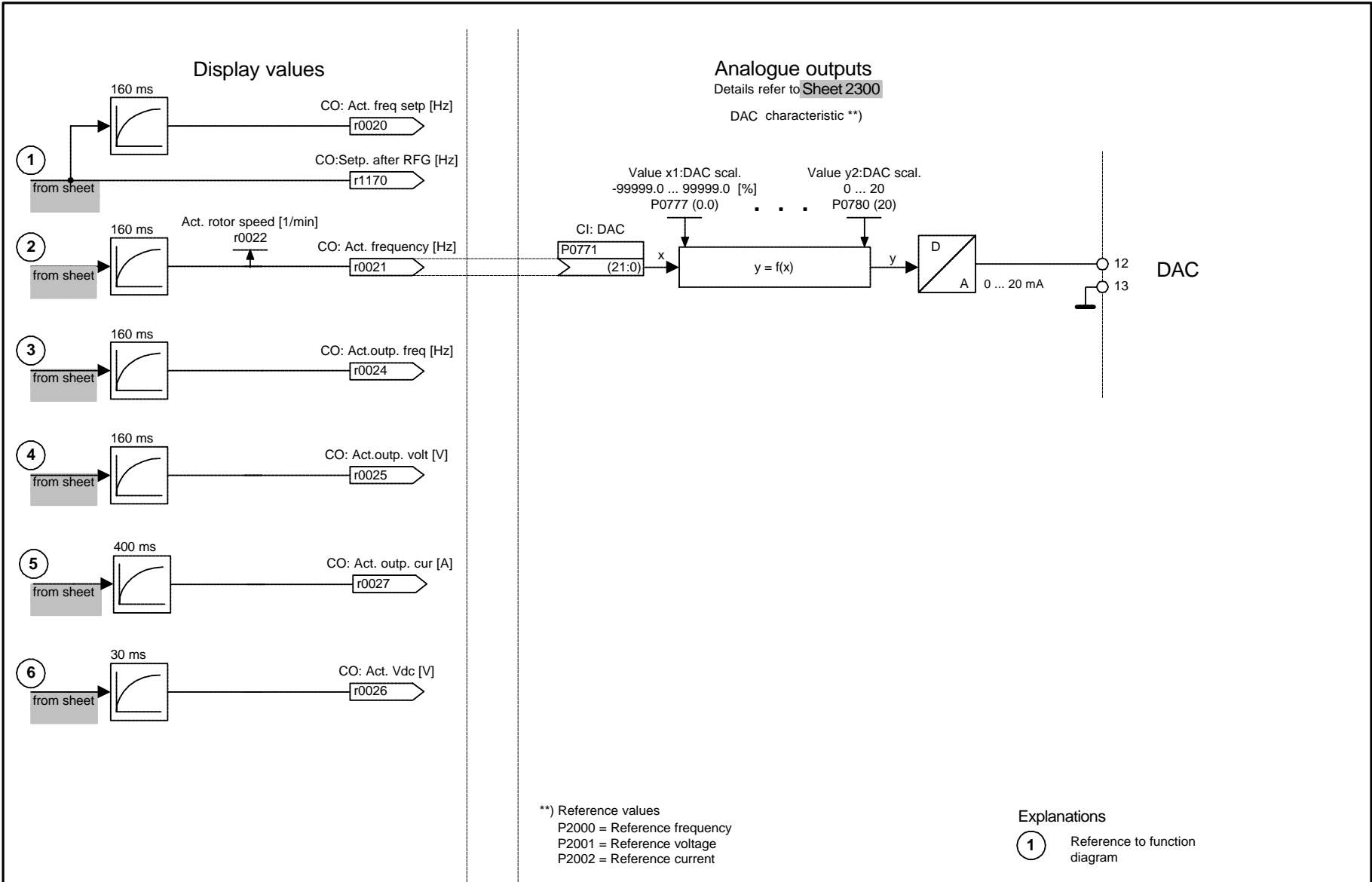

1	2	3	4	5	6	7	8
Control					8000.vsd	Function diagram	
Analog outputs and display values					06.07.2001 V1.13	MICROMASTER 420	
- 8000 -							