

520US/REH, 520DuS/REH 60-100 psi NEMA 4X SCADA pumps fitted with LoadSure® element pumpheads

500 series

Watson-Marlow Bredel

FEATURES

- Flow rates up to 7.1 gph (450 ml/min) at 100psi (7 bar) peak pressure with 520 LoadSure® elements
- 520REH pumphead features large swept volume with sprung rollers for high accuracy, gentle pumping of shear-sensitive fluids
- Robust pumphead construction with PPS (polyphenylene sulphide) track and rotor and stainless steel rollers and bearings
- Precise 2200:1 speed control range from 0.1 to 220rpm in 0.1rpm increments
- Maintenance free brushless DC motor
- NEMA 4X washdown protection for corrosive and heavy duty industrial environments
- Manual control with additional flow calibration and MemoDose for accurate single shot dispensing
- Dual voltage, 115V/230V 50/60Hz



FUNCTIONALITY

Pump drives	520US	520DuS
Manual control		
Full calibration with choice of flow units		•
Simple calibration to display flow in ml/min	•	
Choice of flowrate or speed display	•	•
Remote control		
Run/Stop, direction change, Auto/manual toggle, Leak detector input (via 115V AC industrial logic)	•	•
Remote operation of MemoDose (foot/hand-switch or logic input)	•	•
Analog speed control		
Software programmable inputs; 0-10V, 1-5V or 4-20mA	•	•
Analog outputs; 0-10V (8 bit resolution)	•	
Analog outputs; 0-10V, 4-20mA (8 bit resolution)		•
Keypad/analog input scaling (replacement of diaphragm pumps)		•
Tacho frequency output; 0-1258Hz	•	•
Digital communication		
RS232 network control		•
Security		
Basic security code to protect set-up	•	•

PERFORMANCE

LoadSure® Element tubing flow rates, ml/min(gph)		
Tube Material	Speed	3.2mm
Marprene TH, Bioprene TH, Sta-Pure	0.1 to 220rpm	0.20-450(0.003-7.1)

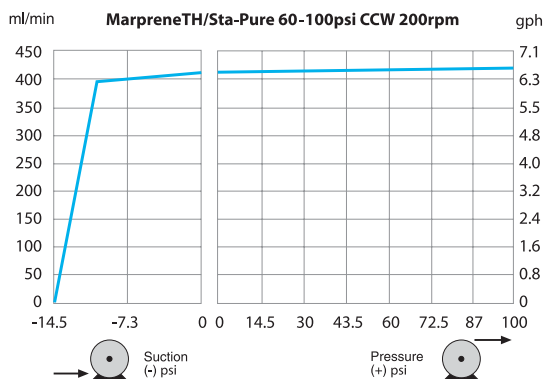

DRAWINGS

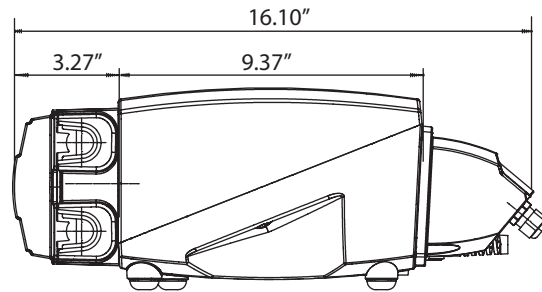
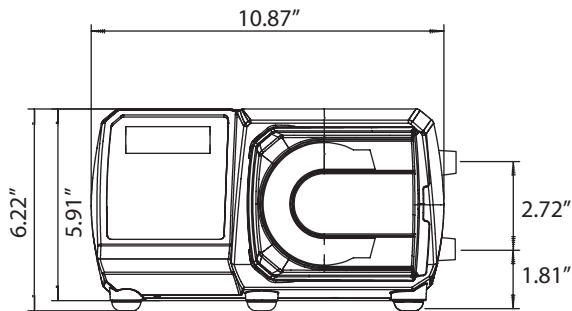

SPECIFICATIONS

	520US, 520DuS
Ingress rating	NEMA 4X
Enclosure	Washdown / watertight / dustproof
Suitability	Corrosion resistant for heavy industrial environments
Humidity	(Condensing) 10-100% RH
Temperature	40F to 104F
Pump weight	23lb 9oz
Control ratio	2200:1
Noise	< 70dB(A) at 1m
Standard	CE, cETLus
Power supply	115/230V 1ph 50/60Hz

MATERIALS OF CONSTRUCTION

Component	Material
Keypad	Polyester
Switch-plate	Glass filled ABS plastic
Rear blanking plate	Stainless steel 304
Drive casework	Pressure die-cast aluminum LM24
Case work coating	Alocrom pre-treatment, exterior grade polyester powder coat
Drive shaft	Electroless nickel plated carbon steel
Pumphead track	PPS (polyphenylene sulphide)
Guard - inner/outer	Polycarbonate
Guard seal	Neoprene
Rotor hub	Stainless steel 316
Roller arms, rotor cover	PPS (polyphenylene sulphide)
Rollers – main/guide	Stainless steel 316
Main roller bearings	Stainless steel with PTFE seals
Drain port and nut	PP (polypropylene)
Drain plug	Hytrel

ORDER INFORMATION

Pump and pumphead product codes

Description	Partcode	Description	Partcode
520REH element pumphead only	053.1011.EH0	520US drive only	056.714S.00A
520US/REH	050.714S.EHA	520DuS drive only	056.715S.00A
520DuS/REH	050.715S.EHA	Leak Detector	059.8121.000

Element product codes

	Industrial LoadSure® elements	Sanitary LoadSure® elements
	Quick-release PVDF connectors	³ / ₄ in Sanitary PVDF connectors
	3.2mm	3.2mm
Marprene TH	902.H032.PFQ	
Sta-Pure	960.H032.PFQ	960.H032.PFT
Bioprene TH		903.H032.PFT

All flow rates shown were obtained pumping water at 68F with zero suction and delivery heads. Watson-Marlow, Bioprene and Marprene are trademarks of Watson-Marlow Limited. Disclaimer: The information contained in this document is believed to be correct but Watson-Marlow Limited accepts no liability for any errors it contains, and reserves the right to alter specifications without notice. LoadSure is a trademark of Watson-Marlow Limited. ® Chem-Sure and ® STA-PURE are registered trademarks of W.L. Gore & Associates Inc. Pumpsil is a trademark of Watson-Marlow Limited. Please state the product code when ordering pumps and tubing.



Watson-Marlow-Bredel Pumps
37 Upton Technology Park
Wilmington, MA 01887
Tel: 800 282 8823 Fax: 978 658 0041
www.watson-marlow.com support@watson-marlow.com