

520S/REM, 520U/REM, 520Du/REM 2-4 bar IP31 pumps fitted with LoadSure® element pumpheads

500 series

Watson-Marlow Pumps Group

FEATURES

- Flow rates up to 1500ml/min at 4 bar (60psi) peak pressure with 520 LoadSure® elements
- 520REM pumphead features large swept volume with sprung rollers for high accuracy, gentle pumping of shear-sensitive fluids
- Robust pumphead construction with PPS (polyphenylene sulphide) track and rotor and stainless steel rollers and bearings
- Precise 2200:1 speed control range from 0.1 to 220rpm in 0.1rpm increments
- High efficiency maintenance free brushless DC motor
- IP31 ingress protection for light industrial and wipedown environments
- Dual voltage, 115V/230V 50/60Hz



2 – 4 bar
30 – 60 psi



Watson-Marlow... Innovation in Full Flow

FUNCTIONALITY

Pump drives	520S	520U	520Du
Manual control			
MemoDose - accurate single shot dispensing	•	•	•
Full calibration with choice of flow units			•
Simple calibration to display flow in ml/min	•	•	
Choice of flowrate or speed display	•	•	•
Remote control			
Run/Stop, direction change, auto/manual toggle, leak detector input (via contact closure or 5V TTL or 24V industrial logic)		•	•
Remote operation of MemoDose (foot/hand-switch or logic input)		•	•
IP31 outputs	•	•	•
Analogue speed control			
Software programmable inputs; 0-10V, 1-5V or 4-20mA		•	•
Analogue outputs; 0-10V		•	
Analogue outputs; 0-10V, 4-20mA			•
Keypad/analogue input scaling (replacement of diaphragm pumps)			•
Tacho frequency output; 0-1258Hz		•	•
Digital communication			
RS232 network control			•
Security			
Basic security code to protect set-up	•	•	•

PERFORMANCE

LoadSure® Element tubing flow rates (ml/min)			
Tube Material	Speed	3.2mm	6.4mm
STA-PURE® Series PCS and Series PFL	0.1 to 220rpm	0.18-390	0.70-1500
Marprene TM, Bioprene TM	0.1 to 220rpm	0.17-370	0.67-1500

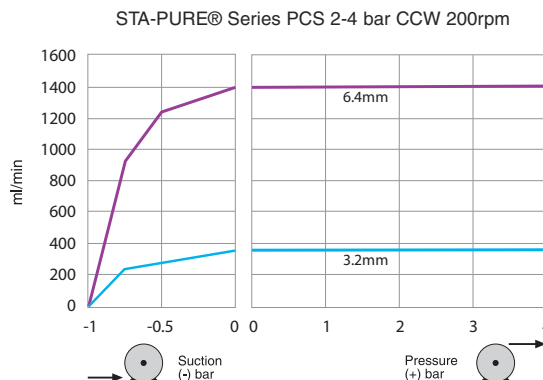
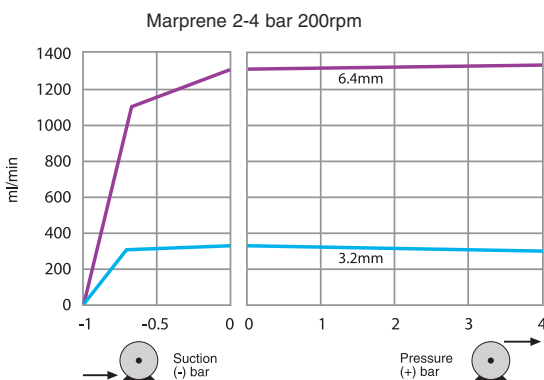

To achieve 4 bar pressure the pump must rotate counter-clockwise

DRAWINGS

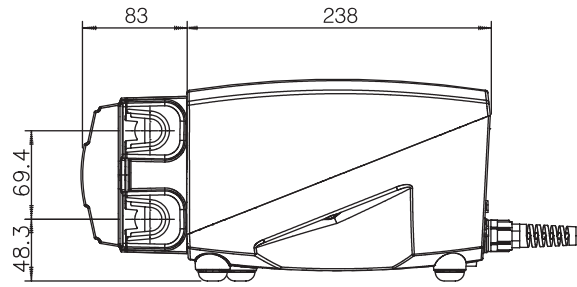
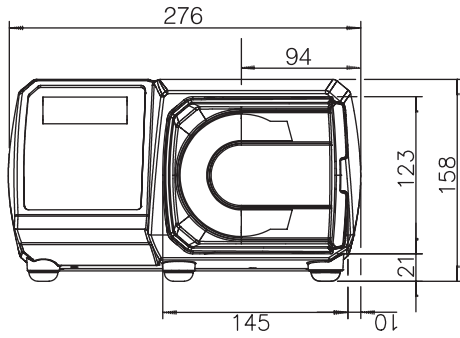

All dimensions in mm

SPECIFICATIONS

	520S, 520U, 520Du
Ingress rating	IP31 / NEMA 2
Enclosure	Wipe-down
Suitability	Dry industrial environments with non-corrosive atmosphere
Humidity	(Non-condensing) 80% to 31C, 88F, decreasing linearly to 50% at 40C, 104F
Temperature	5C to 40C (40F to 104F)
Pump weight	9.82kg, 21lb 10oz
Speed control ratio	2200:1
Torque rating	2.2Nm, continuous duty
Noise	< 70dB(A) at 1m
Standard	CE, cETLus

MATERIALS OF CONSTRUCTION

Component	Material
Keypad	Polyester
Switch-plate	Glass filled ABS plastic
Rear blanking plate	Stainless steel 304
Drive casework	Pressure die-cast aluminium LM24
Case work coating	Alocrom pre-treatment, exterior grade polyester powder coat
Drive shaft	Electroless nickel plated carbon steel
Pumphead track	PPS (polyphenylene sulphide)
Guard	Polycarbonate
Guard seal	Neoprene
Rotor hub	Stainless steel 316
Roller arms, rotor cover	PPS (polyphenylene sulphide)
Rollers – main/guide	Stainless steel 316
Main roller bearings	Stainless steel with PTFE seals
Drain port and nut	PP (polypropylene)
Drain plug	Hytrel

ORDER INFORMATION

Pump and pumphead product codes			
Description	Partcode	Description	Partcode
520REM element pumphead only	053.1011.EM0	520S drive only	056.7131.000*
520S/REM pump	050.7131.EM0*	520U drive only	056.7141.000*
520U/REM pump	050.7141.EM0*	520Du drive only	056.7151.000*
520Du/REM pump	050.7151.EM0*	Leak Detector	059.8121.000

* Supplied as 2.4 metre mains lead without plug. To specify American, European or United Kingdom 2.8m mains lead please specify A, E or U respectively. Replace the

Element product codes				
	Industrial LoadSure® elements Quick-release PVDF connectors		Sanitary LoadSure® elements 3/4 in Sanitary PVDF connectors	
	3.2mm	6.4mm	3.2mm	6.4mm
Bioprene TM			903.P032.PFT	903.P064.PFT
STA-PURE® Series PFL	965.M032.PFQ	965.M064.PFQ	965.M032.PFT	965.M064.PFT
Marprene TM	902.P032.PFQ	902.P064.PFQ		
GORE® Style 400		964.P064.PFQ		

All flow rates shown were obtained pumping water at 20C (68F) with zero suction and delivery heads. Watson-Marlow, Bioprene, Marprene, Pumpsil and PureWeld are trademarks of Watson-Marlow Limited. Disclaimer: The information contained in this document is believed to be correct but Watson-Marlow Limited accepts no liability for any errors it contains, and reserves the right to alter specifications without notice. LoadSure is a trademark of Watson-Marlow Limited. STA-PURE® Series PFL and STA-PURE® Series PCS are registered trademarks of W.L. Gore & Associates Inc. Please state the product code when ordering pumps and tubing.

**WATSON
MARLOW**
Watson-Marlow Pumps Group

Watson-Marlow Pumps Group
Falmouth, Cornwall England TR11 4RU
Tel: +44 (0)1326 370370 Fax: +44 (0)1326 376009
www.wmpg.com info@wmpg.uk
Watson-Marlow...Innovation in Full Flow