



SPX15 DuCoNite® Chemical Duty Hose Pump

Features and Benefits

- High-tech DuCoNite® corrosion resistant surface treatment for protection against corrosive and caustic fluids
- Can run dry continuously
- Accurate ($\pm 1\%$) dosing (metering) capabilities
- Smooth liquid passage without valves, dead corners, or glands
- The material to be pumped does not contact mechanical parts or seals
- Easy maintenance, low cost, short down time
- Only one wearing part: the hose
- Easily and completely cleanable
- Easily adjustable and reversible rotation
- Suitable for high viscosity and densities
- No metal contact or valves
- Safe for use in explosive environments
- No internal back flow (slip)
- High level sensor for pump shutdown in the event of hose failure
- Self priming to 95% vacuum
- Patented direct coupled design with rotor-supporting twin-bearing hub integrated into the pumphead and unique buffer zone to provide protective barrier between pump-head and gearmotor
- Ultra compact footprint with flanged helical gearing: no coupling or drive alignment required
- Optional integral VFD with user friendly speed pot and fwd/off/rev push buttons
- Two year comprehensive warranty

Performance Chart

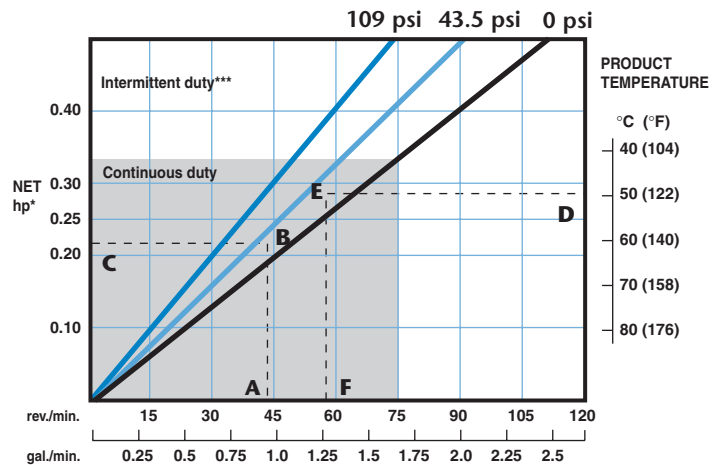

How to calculate speed/horsepower

- A** Flow required, indicates pump speed
- B** Calculated discharge pressure
- C** Horsepower required
- D** Fluid temperature
- E** Calculated discharge pressure
- F** Maximum recommended pump speed**

* Minimum starting torque 500 in-lbs based on starting unloaded at atmospheric discharge pressure. Starting torque can be 2-3X running torque if starting under the load of higher discharge pressures. ** For maximum hose life, speed point (A) should be lower than temperature adjusted speed point (F). See example points (A) thru (F). ***Intermittent duty = 2 hrs max continuous running, 1 hr stop before restart.

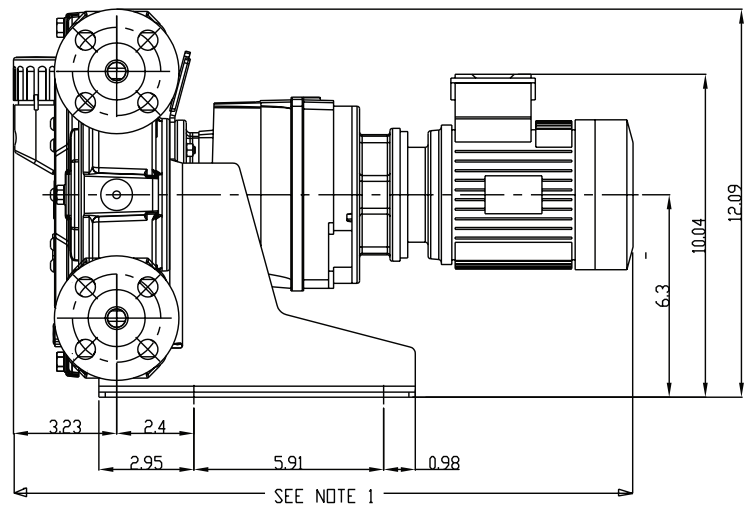
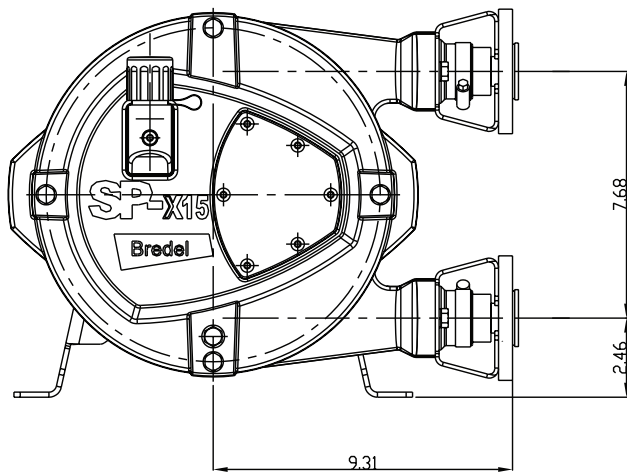

Notes:

1. Dimension is dependent on selection of gearbox and/or motor
2. All dimensions in inches

SPX15

DuCoNite® Chemical Duty Hose Pump

Technical Specifications

- Displacement:** 0.022 gal/rev
- Supply:** 115/230 single phase or 230/460 three phase or 575 three phase
- Operating Speeds:** up to 75 rpm continuous
up to 105 rpm intermittent
- Fluid Temperature Range*:** -4° to 175°F
- Ambient Temperature Range**:** -4° to 113°F
- Hose Lubricant Required:** 0.13 gallons
- Flow Range:** up to 2.3 gpm
- Discharge Pressure:** up to 110 psi
- Suction Pressure:** 28 ft. lift to 30 psi
- Available Hose Materials:** Natural Rubber, BUNA N, EPDM
- Available Insert Materials:** Polypropylene, 316SS
- Fittings:** 3/4" 150# Flange
- High Level Hose Leak Sensor:** NO or NC:
1A max, 250V max, 50 VA max

Materials of Construction

- Pumphead:** DuCoNite® Treated Cast Iron
- Rotor with Integral Shoes:** DuCoNite® Treated Cast Iron
- Bearing Hub:** DuCoNite® Treated Cast Iron
- Cover:** DuCoNite® Treated Cast Iron
- Brackets:** 316SS
- Support Frame:** 16SS
- Hardware:** 316SS
- Hose Clamps:** 316SS
- Shaft:** Alloy Steel
- Seals:** Viton and EPDM
- Pumphead Weight:** 23 lbs
- Estimated Assembly Weight:** 75 lbs

*Consult Watson-Marlow Bredel for lower or higher temperature operation

**Allowable ambient temperature is based on pump capabilities and may be further limited by gearmotor ambient capabilities

The information contained in this document is believed to be correct, but Watson-Marlow Bredel Pumps accepts no liability for any errors it contains, and reserves the right to alter specifications without notice.

Watson-Marlow Bredel Pumps

37 UPTON TECHNOLOGY PARK, WILMINGTON, MA 01887-1018
TEL: 800-282-8823, 978-658-6168 / FAX: 978-658-0041
<http://www.watson-marlow.com>