



SPX32 DuCoNite® Chemical Duty Hose Pump

Features and Benefits

- High-tech DuCoNite® corrosion resistant surface treatment for protection against corrosive and caustic fluids
- Can run dry continuously
- Accurate ($\pm 1\%$) dosing (metering) capabilities
- Smooth liquid passage without valves, dead corners, or glands
- The material to be pumped does not contact mechanical parts or seals
- Easy maintenance, low cost, short down time
- Only one wearing part: the hose
- Easily and completely cleanable
- Easily adjustable and reversible rotation
- Suitable for high viscosity and densities
- No metal contact or valves
- Safe for use in explosive environments
- No internal back flow (slip)
- High level sensor for pump shutdown in the event of hose failure
- Self priming to 95% vacuum
- Patented direct coupled design with rotor-supporting twin-bearing hub integrated into the pumphead and unique buffer zone to provide protective barrier between pump-head and gearmotor
- Ultra compact footprint with flanged helical gearing: no coupling or drive alignment required
- Optional integral VFD with user friendly speed pot and fwd/off/rev push buttons
- Two year comprehensive warranty

Performance Chart

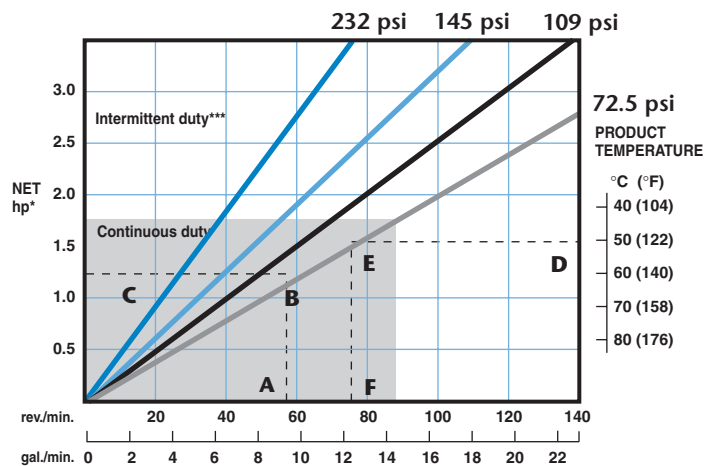

How to calculate speed/horsepower

- A** Flow required, indicates pump speed
- B** Calculated discharge pressure
- C** Horsepower required
- D** Fluid temperature
- E** Calculated discharge pressure
- F** Maximum recommended pump speed**

* Minimum starting torque 3,000 in-lbs based on starting unloaded at atmospheric discharge pressure. Starting torque can be 2-3X running torque if starting under the load of higher discharge pressures. ** For maximum hose life, speed point (A) should be lower than temperature adjusted speed point (F). See example points (A) thru (F). ***Intermittent duty = 2 hrs max continuous running, 1 hr stop before restart.

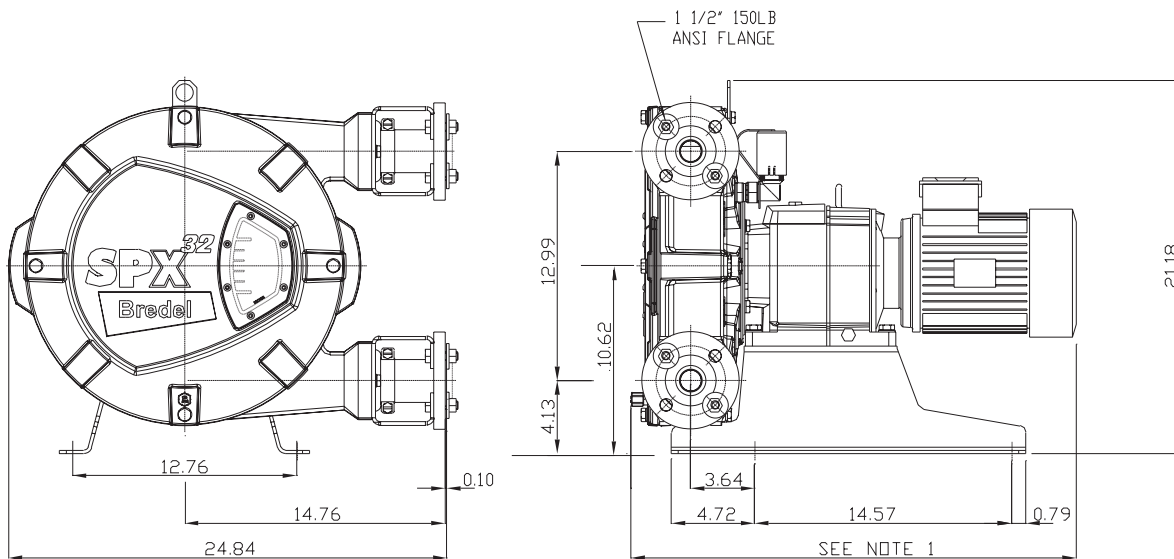

Notes:

1. Dimension is dependent on selection of gearbox and/or motor
2. All dimensions in inches

SPX32 DuCoNite® Chemical Duty Hose Pump

Technical Specifications

- Displacement:** 0.165 gal/rev
 - Supply:** 115/230 single phase or 230/460 three phase or 575V three phase
 - Operating Speeds:** up to 87 rpm continuous up to 120 rpm intermittent
 - Fluid Temperature Range*:** -4° to 175°F
 - Ambient Temperature Range**:** -4° to 113°F
 - Hose Lubricant Required:** 0.8 gallons
 - Flow Range:** up to 20 gpm
 - Discharge Pressure:** up to 232 psi
 - Suction Pressure:** 28ft. lift to 48 psi
 - Available Hose Materials:** Natural Rubber, BUNA N, EPDM, Hypalon
 - Available Insert Materials:** Polypropylene, 316SS, PVDF, PVC
 - Fittings:** 1.5" 150# Flange
 - High Level Hose Leak Sensor:** NO or NC: 1A max, 250V max, 50VA max
- When installing, allow min 40" linear clearance from ports to facilitate hose changing

Materials of Construction

- Pumphead:** DuCoNite® Cast Iron
- Bearing Hub:** DuCoNite® Cast Iron
- Shims:** Titanium
- Flanges and Flange Brackets:** 316SS
- Support Frame:** 316SS
- Internal Hardware:** Titanium, External Hardware: 316SS
- Hose Clamps:** 316SS
- Shaft:** Alloy steel
- Seals:** Viton or EPDM

*Consult Watson-Marlow Bredel for lower or higher temperature operation

**Allowable ambient temperature is based on pump capabilities and may be further limited by gearmotor ambient capabilities

The information contained in this document is believed to be correct, but Watson-Marlow Bredel Pumps accepts no liability for any errors it contains, and reserves the right to alter specifications without notice.

Watson-Marlow Bredel Pumps

37 UPTON TECHNOLOGY PARK, WILMINGTON, MA 01887-1018
TEL: 800-282-8823, 978-658-6168 / FAX: 978-658-0041
<http://www.watson-marlow.com>